

E30 Smart Tool EU w. Connector | P/N: 81501343

Featuring Variable Field Output (VFO) technology, this automation-ready magnetic gripper can be controlled using CANopen protocols to de-stack and pick single or multiple sheets. Adjustability of magnetic strength between 0 and 100% allows use of this magnet on both thin and thick sheets of varying sizes and material type. CANopen communication allows integration of multiple tools on the same CANopen bus, controlled simultaneously.



Specifications

Nominal Maximum Breakaway Force ^{1,2}	124.1 lb	56.3 kg
Nominal Maximum Shear Force ^{1,2}	39.7 lb	18 kg
Nominal Supply Voltage	24 V DC	
Peak Power Draw	1A @ 24 V DC	
Net Weight	1.98 lb	0.9 kg
Connector Type	Male M12x1.0 – 5 Pin – A-coded	
Mounting Options	TOP: Ø6-M8-Ø6 NAAMS pattern (x2)	

De-stack Settings ³	Minimum Thickness for De-stack - mm (in)	0.5 (0.020)	1 (0.039)	2 (0.079)	4 (0.157)
	Partial Actuation	30%	45%	70%	100%

Material Thickness - mm (in)	0.5 (0.020)	1 (0.039)	2 (0.079)	3 (0.118)	4 (0.157)	5 (0.197)	6 (0.236)
Maximum Force ^{1,2,5} - kg (lbs)	6.2 (13.67)	17.3 (38.14)	30.9 (68.12)	48 (105.82)	51.2 (112.88)	56.2 (123.90)	56.3 (124.12)

$$SWL \text{ (Safe Working Load)} = \frac{\text{Maximum Force}^5}{\text{Safety Factor} (\geq 5)}$$

¹ Determined in laboratory environment on SAE1018 Steel with surface roughness 63 micro inches with optimized pole shoes. Many factors contribute to the actual breakaway force and safe working load in each application. Consult a Magswitch Applications Engineer and test the Magswitch in each application before deployment.

² All data applies to unit with flat pole shoes installed.

³ Determined with SAE1018 Steel L=200mm W=200mm.

⁴ Values may vary by +/- 5%.

⁵ Maximum forces listed above are not safe lifting forces. Designer must take into account safety factor when specifying tool. Magswitch recommends SWL = 5:1 for most applications.

Pole shoes required for operation

Standard Kits Available:

Standard Pole Shoe Kit	8800782
Teeth Pole Shoe Kit	8800862
MagMaster: Communication Module for E Series	8800826

WARNING!
Do Not Operate Unless In
Contact With Ferrous Target!

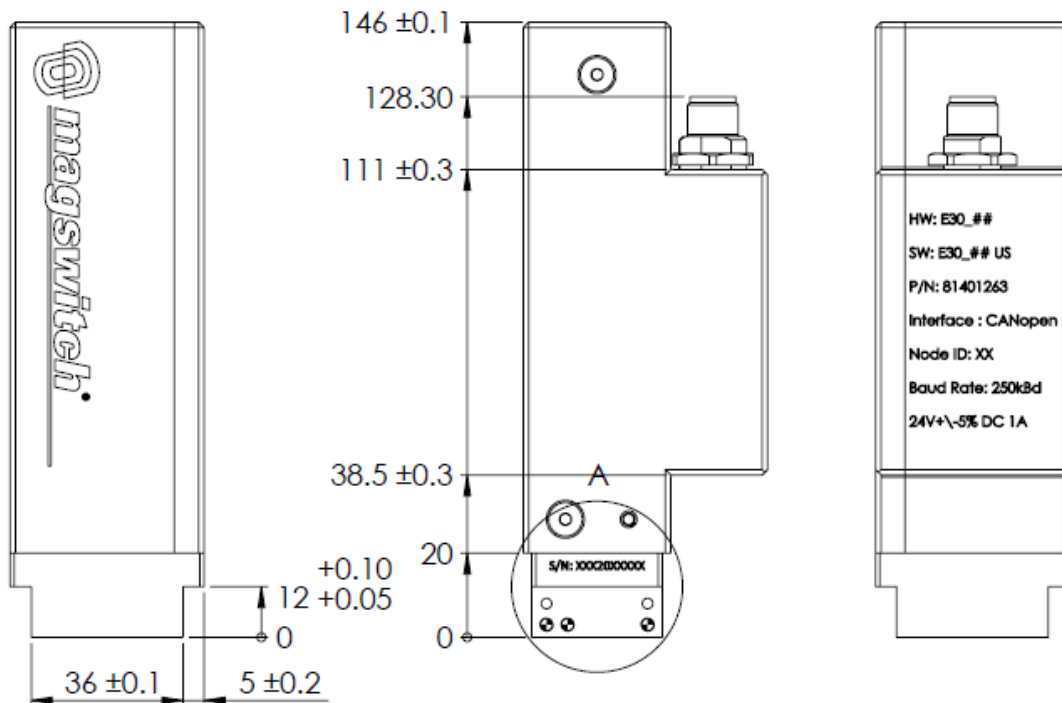
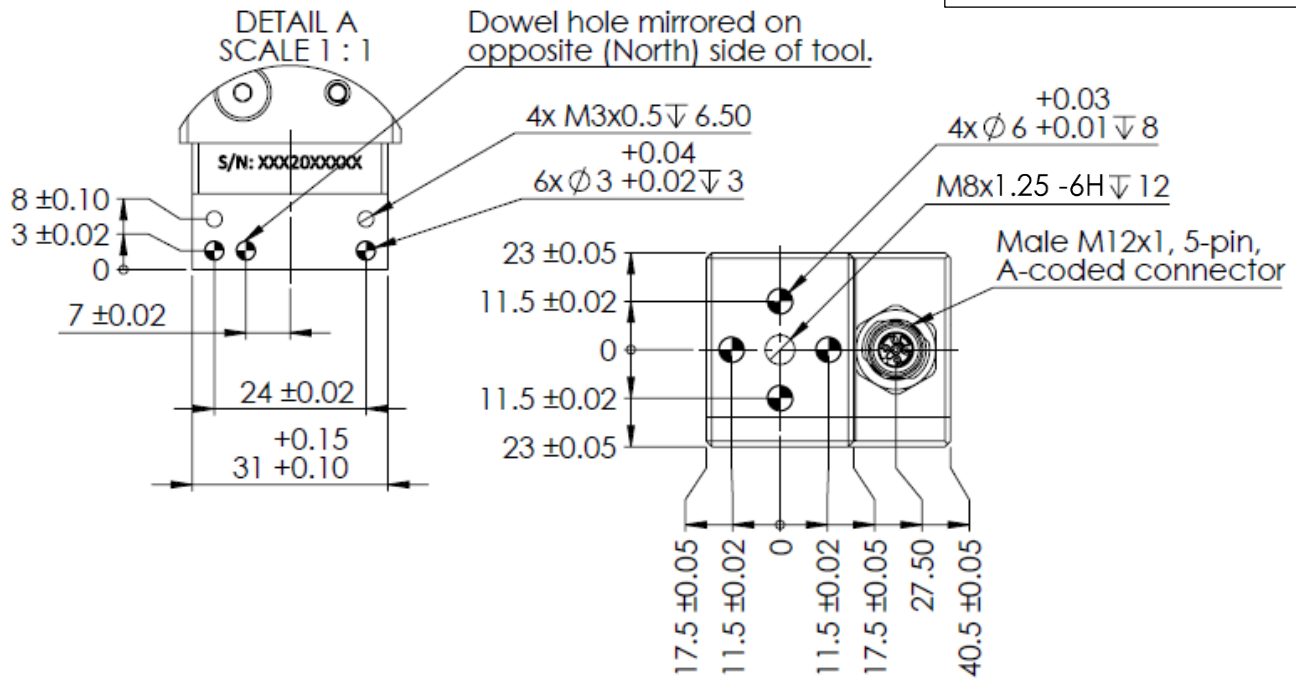

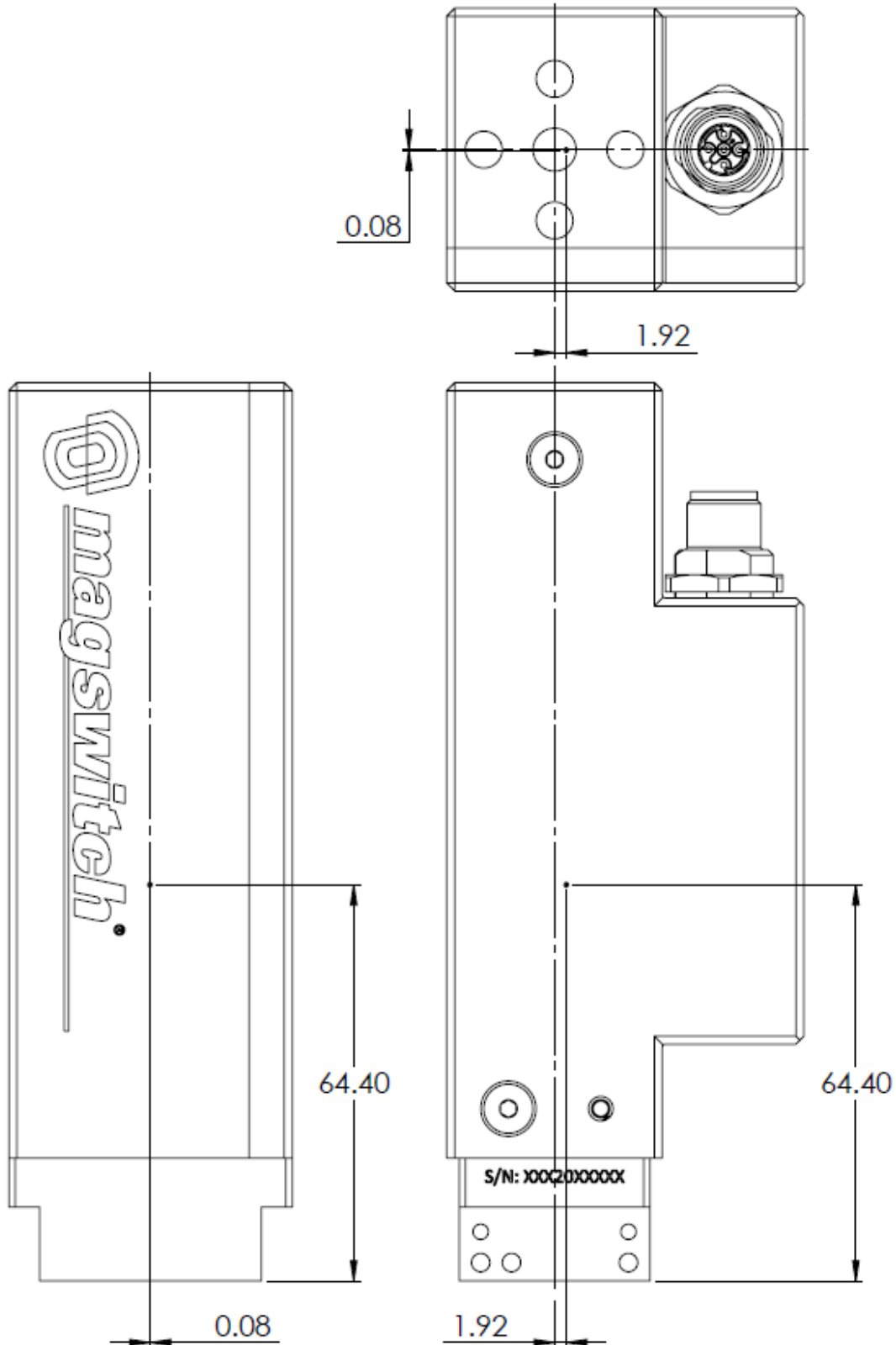
Center of Mass (COM) Information

General Electrical Characteristics

Parameter	Value
Input Voltage Range	24 ± 5% V DC
Rated Current Draw (Continuous and Peak)	1 A DC @ 24 V DC
Connection to tool	Rigid vertical M12 connector
Connector Style	Male M12 – 5 Pin – A-Coded

Ambient Conditions

Parameter	Range
Ambient Temperature (Operation)	-10 to +40 Degrees Celsius
Ambient Temperature (Storage)	-25 to +80 Degrees Celsius
Relative Humidity (non-condensing)	0 to 95%

LED Color Codes

Function/State	Blue LED State	Green LED State
No power to tool	OFF	OFF
Waiting to home magnet	Blinking	Blinking
Magnet actuated OFF	ON	OFF
Magnet actuated ON 100% (Fail-Safe)	ON	ON
Magnet partially actuated	ON	Blinking
Standard calibration routine	Blinks when calibration mode is entered Blinks when steps 1-4 are confirmed	OFF/ON depending on magnet state
Auto-calibration routine	Blinks on entry and exit/confirmation	OFF/ON depending on magnet state

Connector Pinout

Pin #	Function	Logic
1	Signal Shield	-
2	Vin (V+)	+ 24 VDC
3	GND (V-)	GND
4	CANopen bus high	TX/RX high line (D1) (CAN H)
5	CANopen bus low	TX/RX low line (D0) (CAN L)

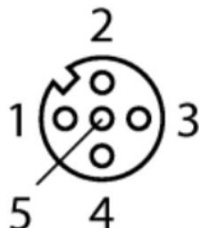

Cable Side: Pin Assignment M12, 5-pin, A-coded, Female Connector (socket-side)

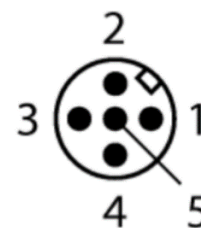

Tool side: Pin Assignment M12, 5-pin, A-coded, Male Connector (pin-side) View

CANopen Configuration Information

CAN Baud Rate	250 kBaud (Note software version on Page 8)
Default CAN Node ID	$14_d = E_h$, See 2a and 2b below for details
Device Terminating Resistor	120 Ω NOT enabled
Master Device Termination	Master device must have line polarization/termination OR: Apply 450-650 Ω pull-up to +5V on high line (D1) (CAN_H) Apply 450-650 Ω pull-down to GND on low line (D0) (CAN_L)

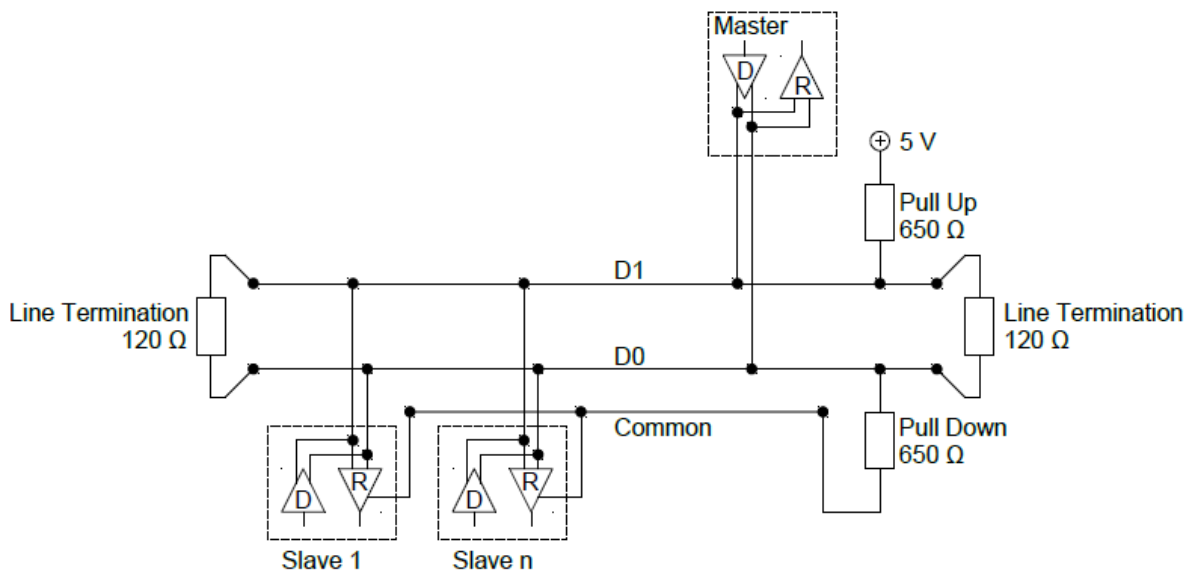

Changing CANopen NodeID

- Check object 2009_h for current CANopen NodeID.
 - Default NodeID = $14_d = E_h$ (Node ID range in Step 2-a)
- Write desired NodeID value to 2009_h.
 - Software Version 15 & above: Acceptable NodeID value range = 1_d-23_d (Defaults to 14 if node ID is out of range)
 - Software Version 14 & below: Acceptable NodeID value range = 1_d-127_d
- To save, write to object 1010_h sub-index 02_h the value 1702257011_d (65766173_h).
- Wait until object 1010_h sub-index 02_h is equal to 1.
- Disconnect and reconnect power.
- The device NodeID will now be changed.

Changing CANopen Baud Rate (Not configurable for software version 15 and above)

For changing tool CANopen baud rates, please consult integration/assembly manual 1101334. Available baud rates are 10, 20, 50, 125, 250, 500, and 1000 kBaud.

CANopen I/O Service Data Objects (SDO's) and Functionality

Type	Object (hex)	Sub Index (hex)	Short Name	Description
Inputs	2400	01	Move Enable	1 = home magnet 2 = move to position set in 2400:02 0 = reset trigger after each move
	2400	02	Set Position	Position 0-100% (increments of 1)
	2400	03	Calibration Trigger	Standard Calibration: 1 = trigger (must be reset to 0 after each trigger in standard calibration) Auto Calibration: 1 = start (with Calibration Mode already set to 1) 999 = exit & don't save 0 = reset trigger after setting 1 or 999
	2400	04	Calibration Select	Select calibration storage options 0-3 (4 possible calibrations)
	2400	05	Sensitivity	default = 0 more sensitive = -x less sensitive = x typical x values = 5, 10, 20
	2400	06	Calibration Mode	0 = standard calibration procedure (good for bin picking, etc) 1 = auto calibrate
Outputs	2500	01	Magnet Position	0-100% (<=2 is considered 0)
	2500	02	Magnet State	0 = OFF 1 = Partial ON 2 = Magnet ON 100% (Fail-Safe)
	2500	03	Calibration State	0 = no South Pole, no North Pole, and no part present in range 1 = only North pole on 2 = only South Pole on 3 = both poles on, but no part present 4 = North, South, part present all within Range
	2500	04	In Calibration	0 = not in Calibration 1 = In Standard Calibration 2 = In Auto Calibration
	2500	05	Calibration Step	0 = not in calibration 1 = waiting for best circuit 2 = waiting for worst circuit 3 = waiting for South Pole 4 = waiting for North pole
	2500	06	Cycle Count	Number of times the tool has been turned on to full power
	2500	07	Home Status	0 = not properly homed 1 = Properly homed
	2500	08	Move Status	0 = not complete 1 = Last set move complete
	2500	09	Serial Number	Magswitch Tool Serial Number
	2500	0A	Magnet Software Version	Magswitch Software Version
	2500	0B	Tool Type	30 for E30, 50 for E50
	2005		CANopen Baud Rate	85 _h = 133 _d = 250 kBaud by default. Consult configuration manual 1101334 before changing
	2009		CANopen Node ID	Refer to Pg.7: Step 2a and 2b for more details on NodeID range E _h = 14 _d by default

4-Step Calibration Procedure

See setup manual 1101340 for more detail.

Step 1

Limiting Position 1 for Calibration Match Signal

Step 2

Limiting Position 2 for Calibration Match Signal

Step 3

South Pole Position for South Pole Signal

Step 4

North Pole Position for North Pole Signal

Object **CalState (2500:03_h)** will return 4 when the contact quality between both poles and the part lie within the zone created by bounding Limiting Position 1, Limiting Position 2, and North and South Pole calibration signals.

Object **CalState (2500:03_h)** will return 2, 3, or 4 if contact quality is equal to or better than the stored South Pole signal.

Object **CalState (2500:03_h)** will return 1, 3, or 4 if contact quality is equal to or better than the stored North Pole signal.

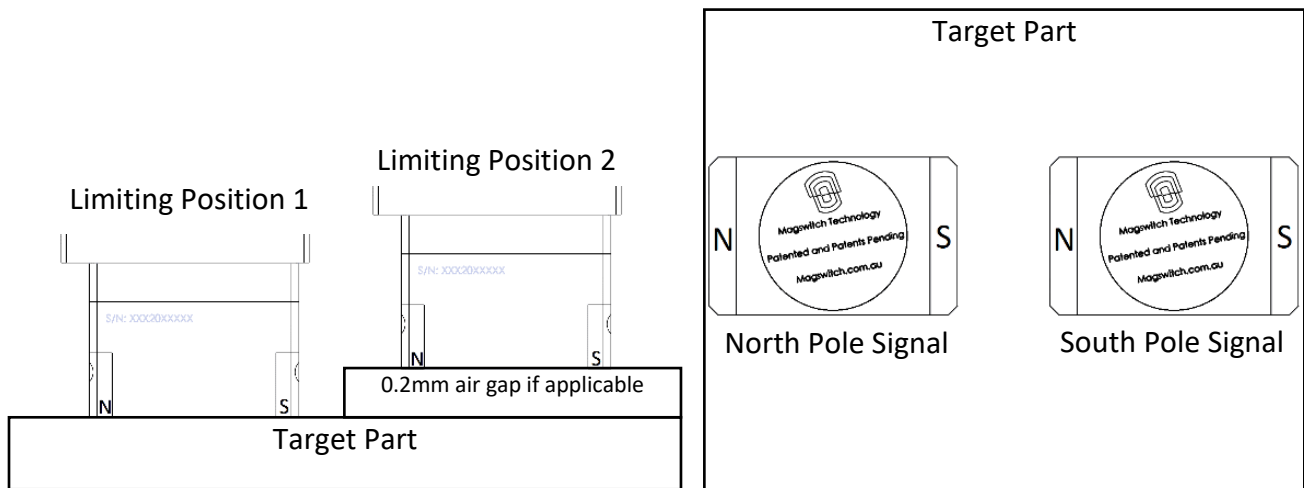

The following flowchart shows the proper CANopen signaling required to enter and set calibrations 0-4. Note that all “output” objects can be polled at any time to determine the current state of the calibration process.

It is critical that the magnet be fully actuated ($setPosition / OutPos = 100$) at each calibration step to guarantee proper field values are stored. **The tool will not allow you to confirm calibration steps 1 through 4 unless the magnet is ON and the green light is lit.**

The supplementary document 1101340 can be provided by Magswitch if additional information regarding calibration procedure is needed.

Auto-Calibration Procedure

Actuate tool OFF and enter auto-calibration mode by setting object $2400:04 = 1_d$ and then writing $2400:03 = 1_d$. Position the tool on the desired part. Once the tool is actuated ON and the green light is lit, the tool records magnetic field strengths in the current configuration and stores them as allowable Part Present boundaries. Add or adjust parts and fixtures to widen the allowable range of field strengths. By writing $2400:03 = 0_d$, auto-calibration parameters are saved and standard operation resumes. Tool should NOT be actuated OFF until auto-calibration is exited and saved otherwise calibration values will be skewed. Tool should not be actuated off-target or calibration range will exceed practical usage and part present functionality will be inaccurate.

E-Series Operational Flowchart

