

CE 440

P/N: 8140976

Tool Features

- Automatic on/off actuation when landing and placing the workpiece in *AUTO mode*.
- 3:1 safety factor.
- Fails safe – no power required once actuated.
- 400 operation cycles before recharging 2h by power supply of 110V / 230V.
- Variable Flux Output (VFO) for de-stacking (1/4in min)
- On tool button
- Coming in 2023 – replaceable and part specific Pole shoes

IMPORTANT note ASME B30.20 standards take precedence over all data provided. We strongly advise operators to be familiar with this standard prior to using any underhook lifter.



Specifications

Maximum Breakaway Force ^{1,2}	1320lb / 600 kg
Breakaway Force @ SWL 3:1	440lb / 200kg
Minimum Thickness for De-Stacking³ – VFO capable	Level 1: 1/4in / 6mm Level 2: 5/16in / 8mm Level 3: 13/32in /
Charging Supply Voltage	110V/230V
Charging Time	2 hours
Number of Cycles per Charge	400
Net Weight	22lb / 10kg
Mounting Option	Single Hoist Ring
Hold Surface (L x W)	4.5in x 2in
Dimensions (L x W x H)	5.9in x 3.3in x 5.9in

1. Determined in laboratory environment on SAE1018 Steel with surface roughness 63 micro inches with optimized pole shoes. Many factors contribute to the actual breakaway force and safe working load in each application. Consult a Magswitch Applications Engineer and test the Magswitch in each application before deployment.

2. All data applies to unit with standard combination V/flat pole shoes installed.

3. Determined with SAE1018 Steel L=200mm W=200mm.

4. Maximum forces listed above are not safe lifting forces. Designer must take into account safety factor when specifying tool. Magswitch recommends SWL = 3:1 for most lifting applications.

$$\text{SWL (Safe Working Load)} = \frac{\text{Maximum Force}^4}{\text{Safety Factor} (\geq 3)}$$

CE 440

P/N: 8140976

Specifications

CE 440	Air gap <0.1mm	Air gap 0.1 to 0.3mm	Air gap 0.3 to 0.5mm
Material Thickness mm [in]	Max. Load kg [lbs]	Max. Load kg [lbs]	Max. Load kg [lbs]
4 [0.157]	35 [77]	30 [66]	30 [66]
6 [0.236]	70 [154]	65 [143]	60 [132]
10 [0.393]	135 [297]	130 [286]	120 [264]
16 [0.629]	190 [418]	185 [407]	170 [374]
20 [0.787]	200 [440]	190 [418]	180 [396]

Drawings

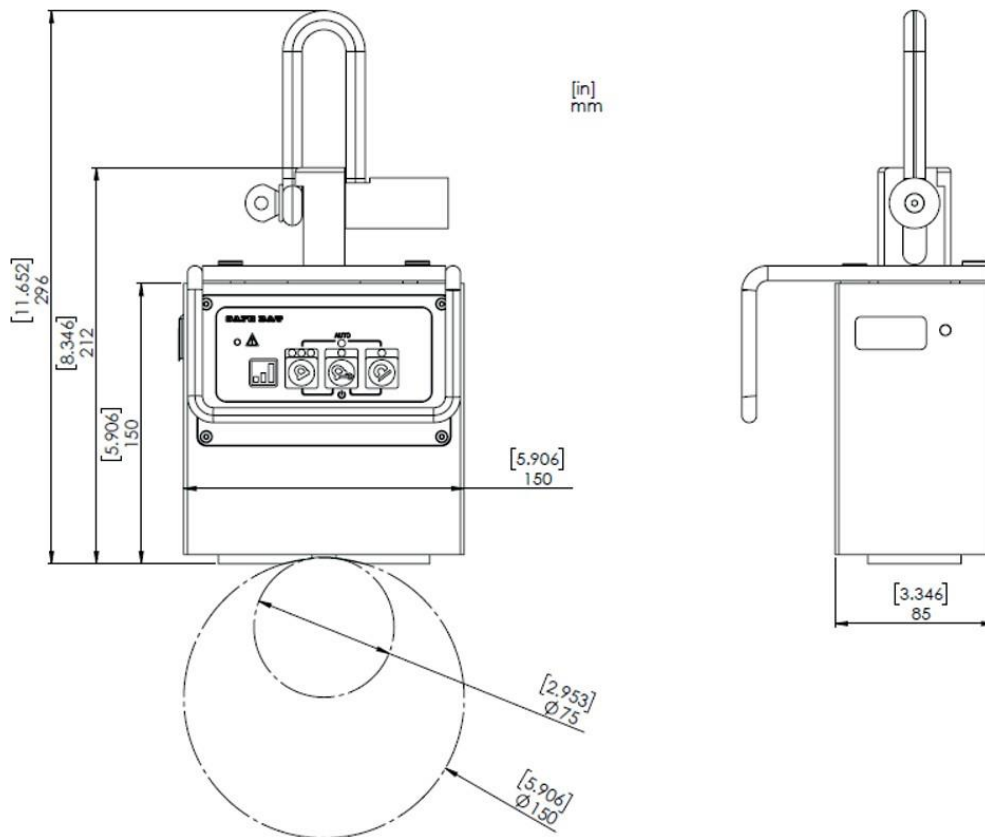

IMPORTANT note ASME B30.20 standards take precedence over all data provided.
We strongly advise operators to be familiar with this standard prior to using any underhook lifter.

MAGSWITCH TECHNOLOGY INC. | 1355 Horizon Avenue | Lafayette
Colorado 80026 | United States | +1 (303) 468.0662 | sales@magswitch.com

CE 440
8140976 / REV03

Subject to technical and color changes. No liability for errors and misprints assumed. © Magswitch Technology Inc. 2023