

STACKED SAVR FEATHERBOARD | P/N: 88001695

Summary

The SAVR stacked featherboard upgrade allows a standard SAVR featherboard to be converted to a Stacked featherboard assembly capable of delivering featherboard force to a vertical workpiece at two points, one at the base and one several inches higher. This keeps workpieces that are being cut on their side (for example bandsaw resaw operations) pressed firmly and safely against the fence.

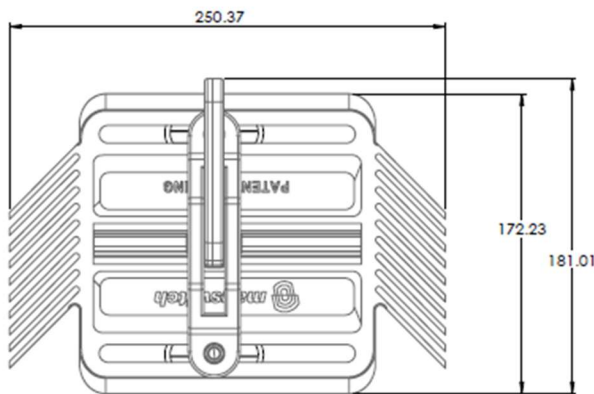

STACKED SAVR FEATHERBOARD KIT ONLY

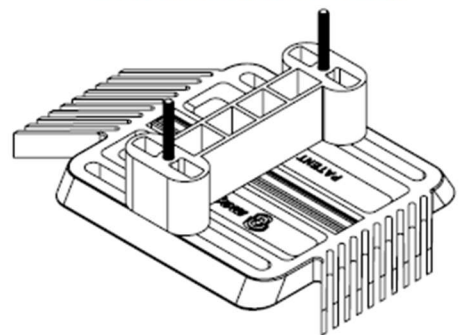

PARTS IN GREY SOLD SEPARATELY (81101513)

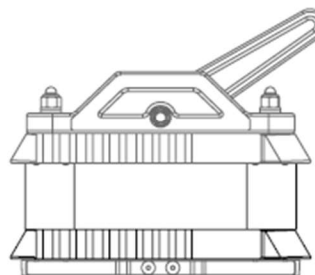
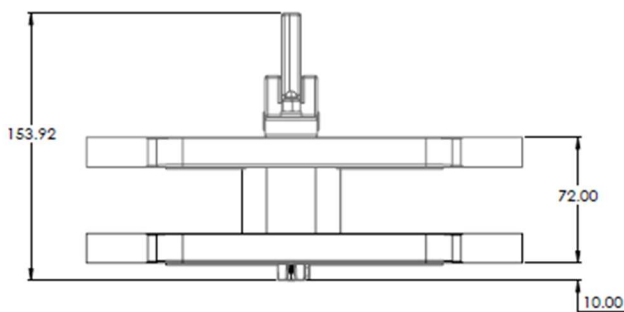



STACKED SAVR FEATHERBOARD

P/N: 88001695

+ 1(303) 468.0662

magswitch.com

User Instructions

1. Remove the nuts that hold the clamping lever down and remove the clamping lever
2. Replace the bolts that came with the SAVR Featherboard with the longer ones included in the Stacked Featherboard Kit.
3. Place the spacer from the Stacked Featherboard Kit on top of the featherboard body with the bolts through the holes in the spacer.
4. Place the additional featherboard body from the Stacked Featherboard Kit over the spacer with the bolts through the slots.
5. Put the clamping lever on the top of the featherboard assembly with the bolts through the holes in the clamping lever.
6. Put two washers and a nut onto the end of each bolt, tighten nuts to proper fit with the same process used to setup the SAVR Featherboard.