

Miller CoPilot MagBase 10 Operation Manual (88002010)

Safety:

- ***Robot MUST be operated in Collaborative Mode ONLY! Speed is limited to 250mm/s.*** Deviating from this specification may result in an unsafe or dangerous condition.
- ***Only lift the MagBase using the two handle cutouts in the platform.*** Items or body parts between the gripping surface of the magnet and ferromagnetic material or MagBase frame are at risk of crushing and impact forces.
- ***Never exceed the max rated load*** of the Magswitch magnet. This may result in an unsafe or dangerous condition.
- ***DO NOT attempt to disassemble or alter the device*** in any way. This will void the warranty and may result in an unsafe or dangerous condition. There are no user-serviceable components inside.
- ***Do not turn the magnet 'ON' unless it is in contact with ferromagnetic metal.*** Actuation off-target will generate a strong, static, projected magnetic field which can accelerate, draw-in, and trap ferromagnetic material and damage magnetic storage media.
- ***Always inspect the tool*** to ensure that it is in good working order before and periodically during use.
- ***Always confirm magnets are making flush contact with target surface.*** Debris between magnet and target surface or improper contact will reduce magnet performance which may result in a dangerous condition.
- ***Avoid sudden jerking or shock force*** as this may exceed magnet holding capacity. Consider use of shear stops or other secondary methods, such as soft starts and stops to prevent loss of magnetic circuit.
- ***DO NOT expose the magnet to temperatures greater than 176°Fahrenheit (80°Celsius).*** High temperatures will permanently degrade the magnet's effectiveness and may result in an unsafe condition.
- ***Not recommended for painted or finish coated surfaces without proper testing and advice*** as these may reduce the magnetic bond, breakaway force and shear performance. The magnet may damage the surface finish. Contact supplier for air gap data.
- This product contains PTFE or Lithium based lubricant. For MSDS information contact Magswitch.

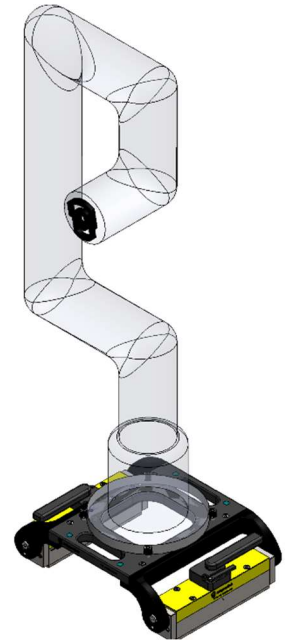

WARNING: This product can expose you to chemicals including toluene, nickel and tetrafluoroethylene, which are known to the State of California to cause birth defects or other reproductive harm. For more information, go to www.P65Warnings.ca.gov

Assembly:

A complete MagBase consists of a minimum of two MagWing magnets and a central platform which spans between the magnets. Multiple variants of the central platform are available or it may be custom designed. The process to assemble is the same for each variant.

1. Press robot mounting dowel pins into platform before assembly. See Commissioning section for more detail.
2. Connect one Magwing to one side of the central platform by aligning the MagWing swivel arm dowel pins (pre-installed) with the central platform dowel holes on one side and press the central platform and MagWing together.

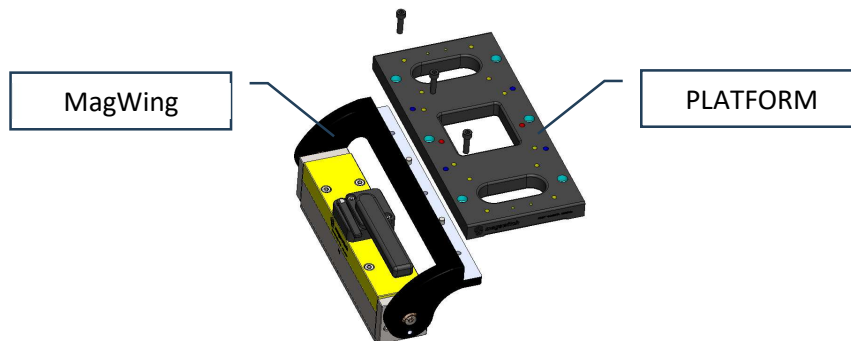

3. Apply medium duty threadlocker such as Loctite 242(Blue) and install three supplied M8X30 SHCS fasteners and torque to 15N-m to secure the platform to the MagWing.



4. Repeat steps (1) and (2) for all MagWing locations.

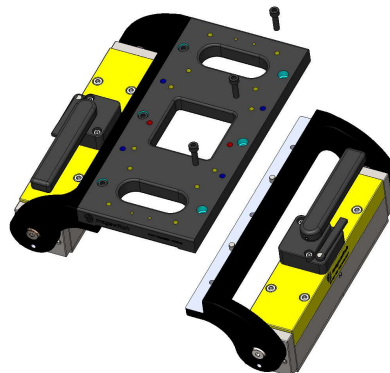

Operation:

Use caution when lifting the MagBase, may require multi-person or equipment assisted lift. When lifting by hand, only lift the MagBase using the two handle cutouts in the platform to avoid crushing hazard between pivoting magnets of MagWings and frame.

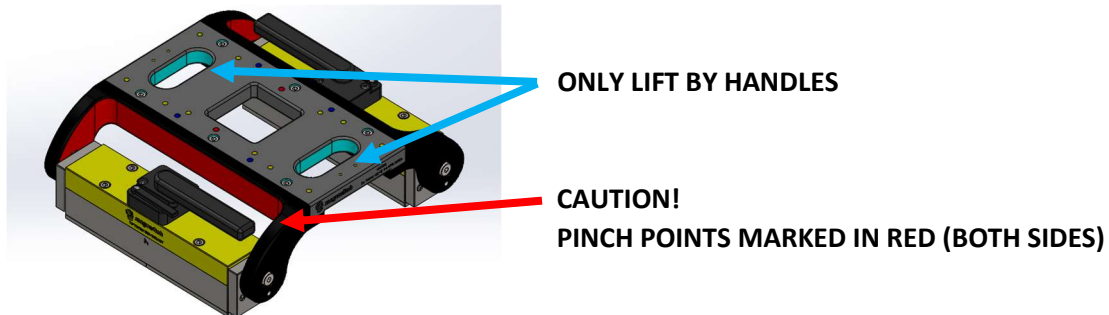

To turn the magnet base ON:

- Position the magnetic base in contact with ferromagnetic material such as low carbon steel.
- **IMPORTANT:** The bottom surface of each MagWing should be in flat, flush contact with the target. On curved or round surfaces, the notched area of the bottom surface of the MagWing should match the contours of the object to which the magnet will be adhered.

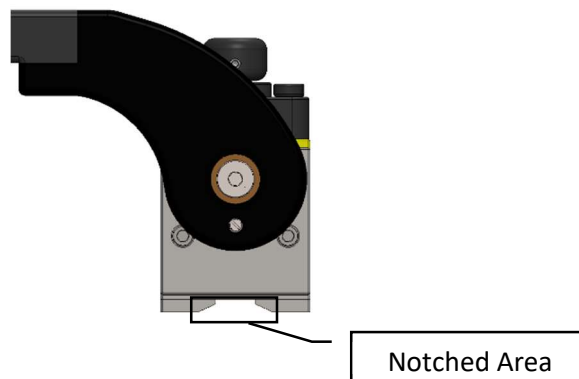

NOTE: Holding force decreases when...

- Surface contact decreases.
- Target material thickness decreases.
- Target material alloy deviates from low carbon 1018 steel.
- “Air gaps” are present such as paint buildup, rust, or non-ferromagnetic materials between the magnet and the target surface.

- Turn the actuation lever on a MagWing clockwise 180°. As the actuation lever is turned the assembly will click as the ratchet advances.

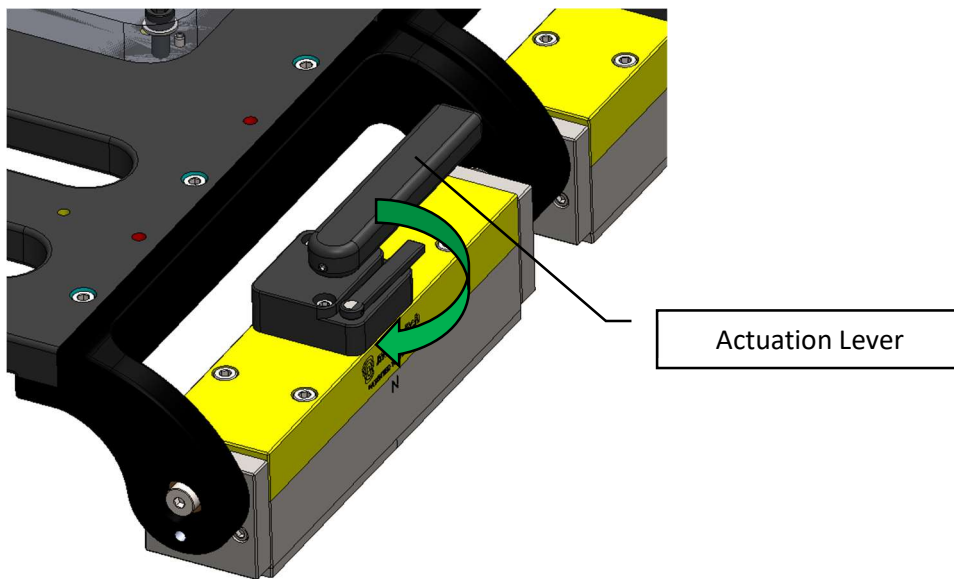

- The ON state is achieved when the actuation lever points to the “MAX” engraving on the ratchet cover.
- Repeat for each MagWing attached to the MagBase.
- The MagBase will not reach full strength until all levers are rotated fully to the “MAX” positions.

To turn the magnet OFF:

- Prior to deactivation, ensure MagBase is adequately supported to prevent unsafe conditions when magnets are released.
- Place one hand on actuation lever and open the ratchet release.

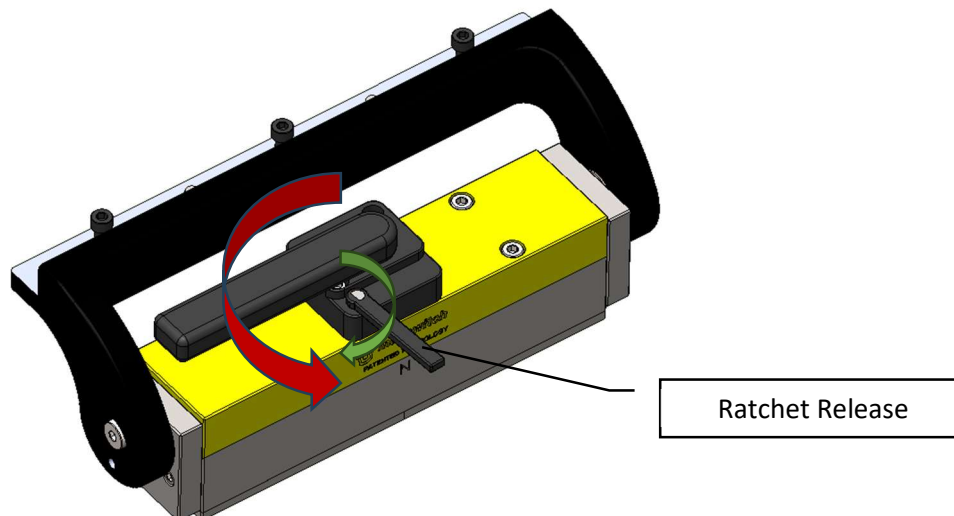

- While ratchet release is open, rotate the actuation lever counterclockwise 180° until the knob points to the “OFF” engraving on the ratchet cover.
 - **WARNING:** the knob can rotate backwards rapidly if the target material is thin (or not present).
 - IF for some reason the magnet was actuated off-target or if the magnet was peeled from a thin target while activated, take care to not get fingers caught between the actuation knob/lever and yellow cap. This can pose a pinch hazard.
- Repeat for all MagWings on the MagBase.
- When all magnets are fully OFF, there will be no attractive force between the base and the substrate material.

Commissioning:

⚠ WARNING: ROBOTS MOUNTED TO THIS BASE MUST BE OPERATED IN COLLABORATIVE MODE ONLY! DEVIATION FROM THIS SETTING MAY RESULT IN AN UNSAFE CONDITION!

After the MagBase is placed in the desired mounting location and activated, the robot may be installed. Please follow the robot manufacturer guidelines for robot installation. The hardware included and steps below outline the process for your convenience.

1. See below for the bolt pattern location and correct fasteners for mounting the robot:
 - a. **NOTE:** The Miller Magbase 10 Pattern Mounts to the Pedestal, **NOT** Directly to the Robot.

ROBOT	PATTERN	BOLT	TORQUE
Miller CoPilot	203.2x203.2	(6) M12x1.75x30	32 N-m

*Overview of Specific Magbase Weight and Dimentions at End of Spec Sheet

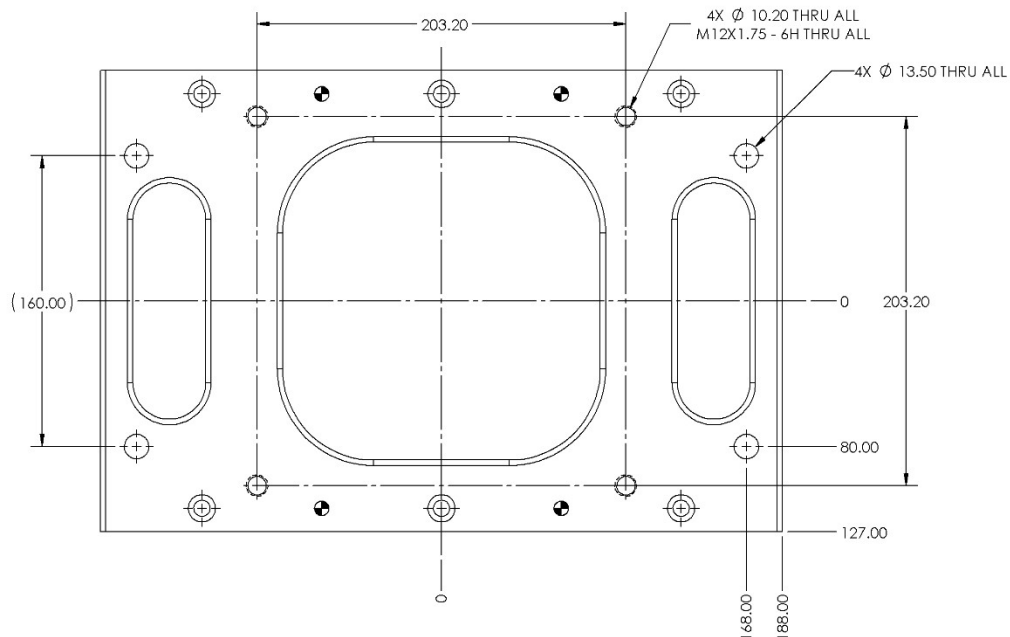

2. Align Robot base with mounting holes and seat robot to platform.

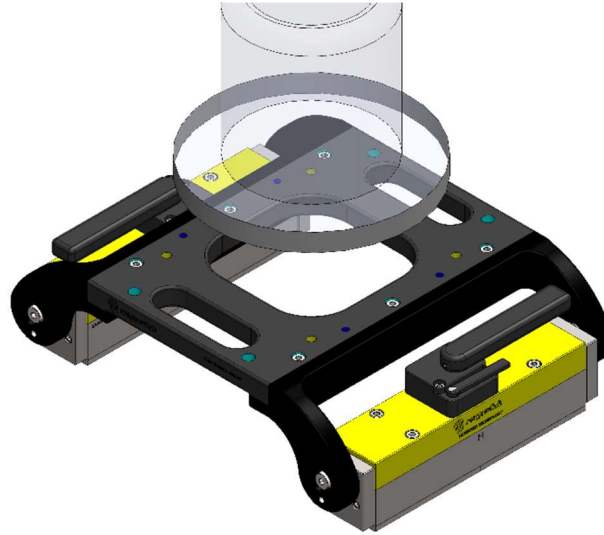

3. Install provided M12x1.75x30 fasteners with medium duty thread locker such as Loctite 242(Blue) and torque to robot manufacturer specifications. See table in step 1 for quick reference.

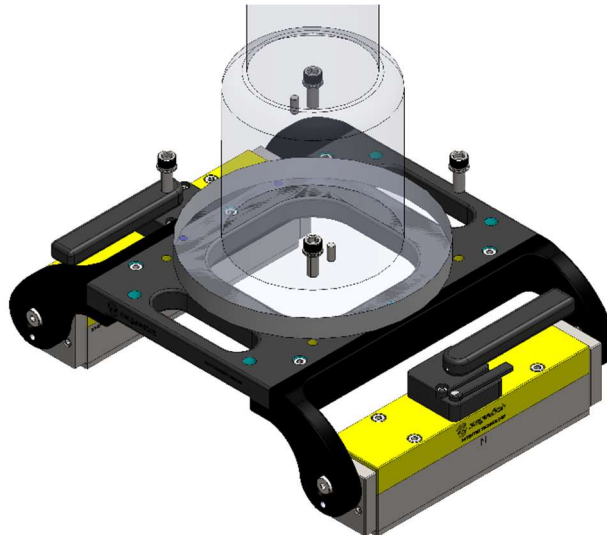

Capability:

⚠ WARNING: ROBOTS MOUNTED TO THIS BASE MUST BE OPERATED IN COLLABORATIVE MODE ONLY! DEVIATION FROM THIS SETTING MAY RESULT IN AN UNSAFE CONDITION!

The Miller MagBase 10 assembly has been designed to support the maximum payload and reach for the Miller CoPilot Cobot in collaborative mode only.

Miller CoPilot

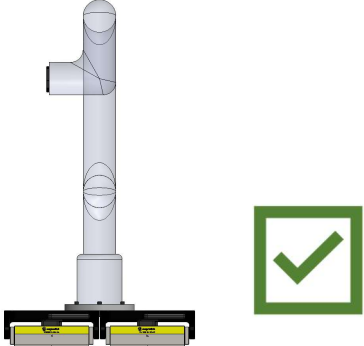
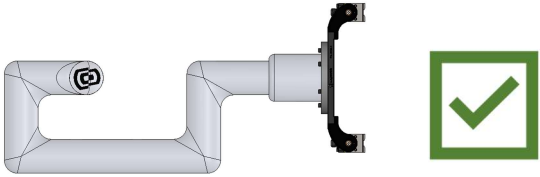
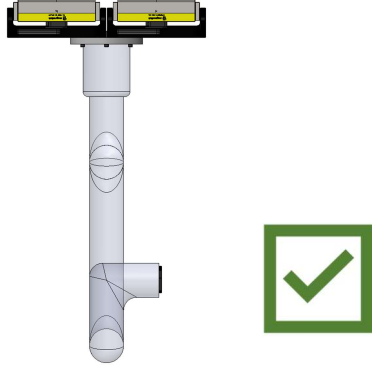

Only mount the MagBase in the following orientations on 12.7mm (0.5”) thick or greater low carbon steel:

NORMAL (FLOOR)	
SHEAR (WALL)	
INVERTED (CEILING)	

Applications requiring attachment to round surfaces, coated surfaces, thinner surfaces, or differing material grades must be reviewed by Magswitch technical experts. Contact Magswitch engineers for support through applications@magswitch.com.

Repeatability: Note that there could be up to 0.2mm (0.008”) of clearance between the bushings and shoulder screws in the MagWings. Please consider this in your application prior to deployment.

Customers are responsible for verifying the safe operation of the MagBase within their application.

Notes on Electrical Isolation:

This magnetic pivot base is outfitted with conductive bushings and the MagWings are NOT isolated from the platform/robot.

Miller MagBase 10 Overview:

MagBase Kit	Compatible Robots	Net Weight kg (lb)
88002010	Miller CoPilot	30.7 (67.7)

Miller MagBase 10 – 88002010

