

ELAY50X5 Smart Tool | P/N: 81401320

Featuring Variable Field Output (VFO) technology, this automation-ready magnetic gripper can be controlled using CANopen protocols to de-stack and pick single or multiple sheets. Adjustability of magnetic strength between 0 and 100% allows use of this mega magnet on both thin and thick sheets of varying sizes and material type. CANopen communication allows integration of multiple tools on the same CANopen bus, controlled simultaneously.

NOTE: Base tool does not ship with 8800924 EOAT bracket (black at right)



Specifications

| | | |
|---|--|---------|
| Maximum Breakaway Force ^{1,2} | 2537 lb | 1151 kg |
| Maximum Shear Force ^{1,2} | 508 lb | 230 kg |
| Nominal Supply Voltage | 24 V DC | |
| Peak Power Draw | 5.5 A @ 24 V DC | |
| Net Weight | 33.95 lb | 15.4 kg |
| Connector Type | Power: Male 7/8" - 4-Pin - A-coded Data: Male M12x1.0 - 5 Pin - A-coded | |
| Mounting Options | SIDE: Ø8-M8-M8-Ø8 pattern (x2) | |

| Material Thickness - mm (in) | 1.9 (0.075) | 2.7 (0.106) | 6.35 (0.250) | 8 (0.315) | 10 (0.394) | 19.05 (0.750) |
|--|----------------|----------------|-----------------|---------------|----------------|------------------|
| Maximum Force ^{1,2,5} - kg (lbs) | 176 (388) | 333 (734) | 860 (1896) | 864 (1906) | 1090 (2404) | 1151 (2537) |

| De-stack Settings ³ | Minimum Thickness for De-stack mm (in) | 1 (0.039) | 2 (0.079) | 3 (0.118) | 4 (0.157) | 5 (0.197) | 6 (0.236) |
|-----------------------------------|---|--------------|--------------|--------------|--------------|--------------|--------------|
| | Partial Actuation | 22% | 27% | 33% | 38% | 40% | 44% |

$$SWL \text{ (Safe Working Load)} = \frac{\text{Maximum Force}^5}{\text{Safety Factor} (\geq 3)}$$

¹ Determined in laboratory environment on SAE1018 Steel with surface roughness 63 micro inches with optimized pole shoes. Many factors contribute to the actual breakaway force and safe working load in each application. Consult a Magswitch Applications Engineer and test the Magswitch in each application before deployment.

² All data applies to unit with standard combination V/flat pole shoes installed.

³ Determined with SAE1018 Steel L=200mm W=600mm.

⁴ Values may vary by +/- 5%.

⁵ Maximum forces listed above are not safe lifting forces. Designer must take into account safety factor when specifying tool. Magswitch recommends SWL = 5:1 for most lifting applications.

Pole shoes required for operation

Standard Kits Available:

| | |
|----------|---------------------------------|
| 88001109 | ELAY50x5 Standard Pole Shoe Kit |
| 8800924 | ELAY50x5 Standard EOAT Bracket |

WARNING!
Do Not Operate Unless In Contact With
Ferrous Target!

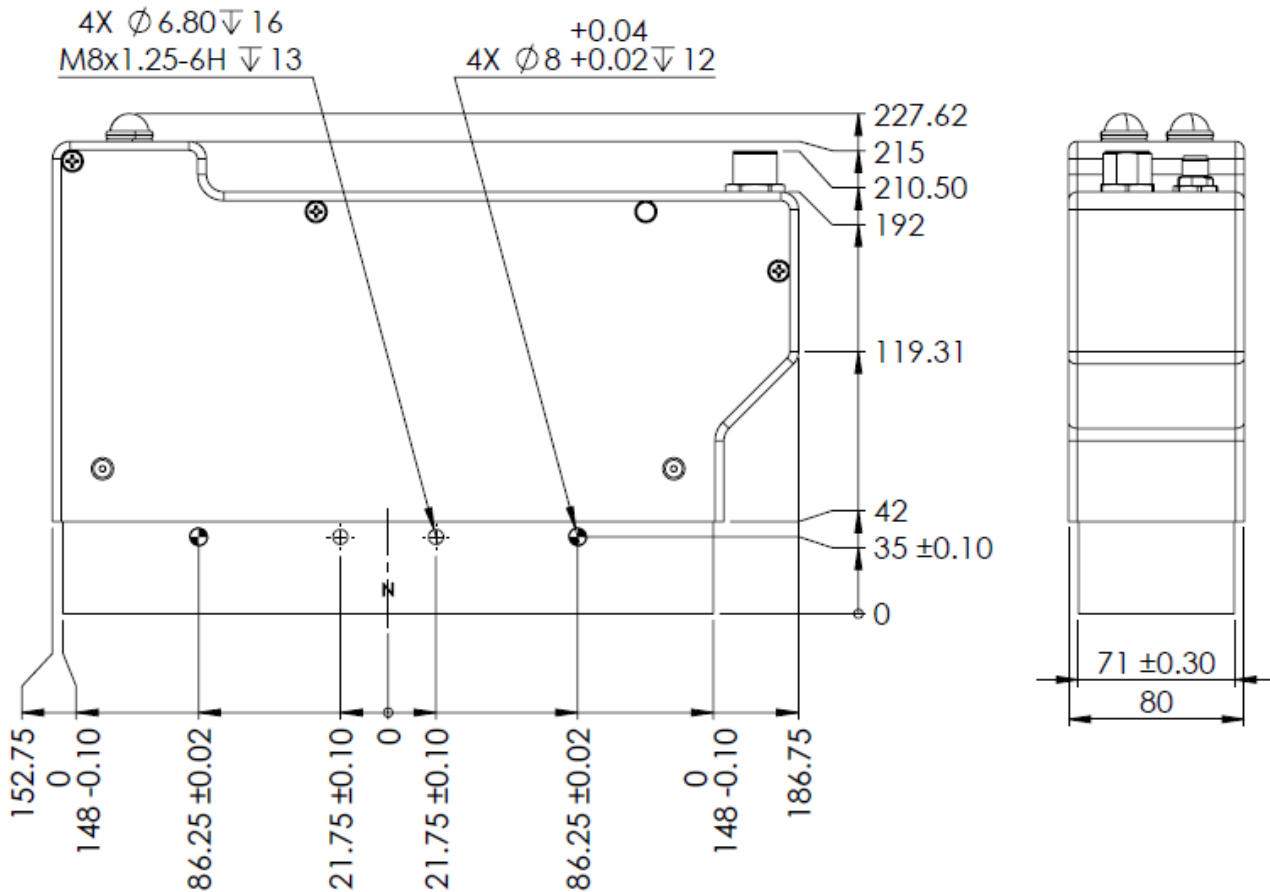
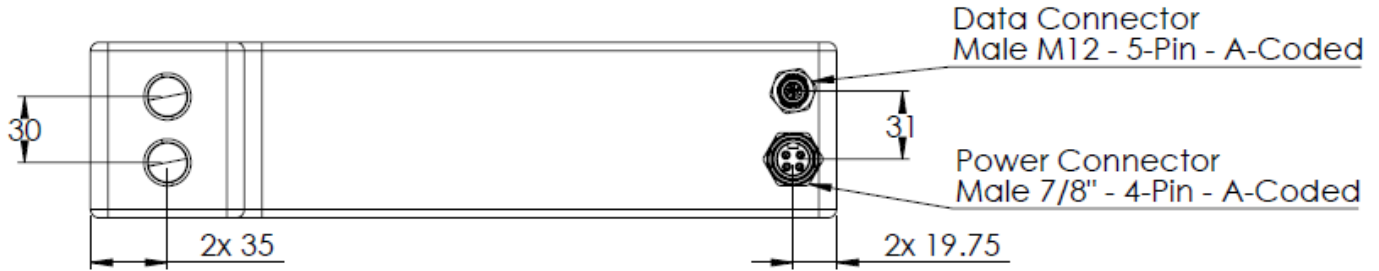

Pole Shoes Sold Separately



General Electrical Characteristics

| Parameter | Value |
|---------------------------------|--|
| Input Voltage Range | 24 ± 5% V DC |
| Rated Current Draw (Peak) | 5.5 A DC @ 24 V DC |
| Rated Current Draw (Continuous) | 0.65 A DC @ 24 V DC |
| Connector Style | Power: Male 7/8" – 4 Pin – A-Coded Data: Male M12 – 5-Pin – A-Coded |

Ambient Conditions

| Parameter | Range |
|------------------------------------|----------------------------|
| Ambient Temperature (Operation) | -10 to +40 Degrees Celsius |
| Ambient Temperature (Storage) | -25 to +80 Degrees Celsius |
| Relative Humidity (non-condensing) | 0 to 95% |

LED Color Codes

| Function/State | Blue LED State | Green LED State |
|-------------------------------------|--|----------------------------------|
| No power to tool | OFF | OFF |
| Waiting to home magnet | Blinking | Blinking |
| Magnet actuated OFF | ON | OFF |
| Magnet actuated ON 100% (Fail-Safe) | ON | ON |
| Magnet partially actuated | ON | Blinking |
| Standard calibration routine | Blinks when calibration mode is entered Blinks when steps 1-4 are confirmed | OFF/ON depending on magnet state |
| Auto-calibration routine | Blinks on entry and exit/confirmation | OFF/ON depending on magnet state |

Connector Pinout(s)

Power Connector (7/8" 4-Pin)

| Pin # | Function | Logic |
|-------|--|----------|
| 1 | Vin (V+) | + 24 VDC |
| 2 | Vin (V+) (internally connected to pin 1) | + 24 VDC |
| 3 | GND (V-) | GND |
| 4 | GND (V-) (internally connected to pin 3) | GND |



Cable Side: Pin Assignment 7/8", 4-pin, A-coded, Female Connector (socket-side) View



Tool side: Pin Assignment 7/8", 4-pin, A-coded, Male Connector (pin-side) View

Data Connector (M12 5-Pin)

| Pin # | Function | Logic |
|-------|---------------------------|------------------------------|
| 1 | Signal Shield | - |
| 2 | (Internally Disconnected) | - |
| 3 | GND | GND |
| 4 | CANopen bus high | TX/RX high line (D1) (CAN H) |
| 5 | CANopen bus low | TX/RX low line (D0) (CAN L) |

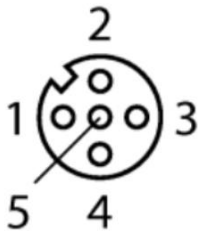

Cable Side: Pin Assignment M12, 5-pin, A-coded, Female Connector (socket-side) View

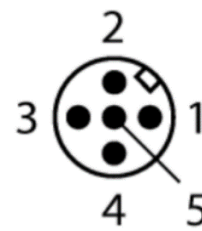

Tool side: Pin Assignment M12, 5-pin, A-coded, Male Connector (pin-side) View

CANopen Configuration Information

| | |
|-----------------------------|--|
| CAN Baud Rate | 250 kBaud, configurable |
| Default CAN Node ID | 127 _d = 7F _h , configurable |
| Device Terminating Resistor | 120 Ω NOT enabled |
| Master Device Termination | Master device must have line polarization/termination OR: Apply 450-650 Ω pull-up to +5V on high line (D1) (CAN_H) Apply 450-650 Ω pull-down to GND on low line (D0) (CAN_L) |

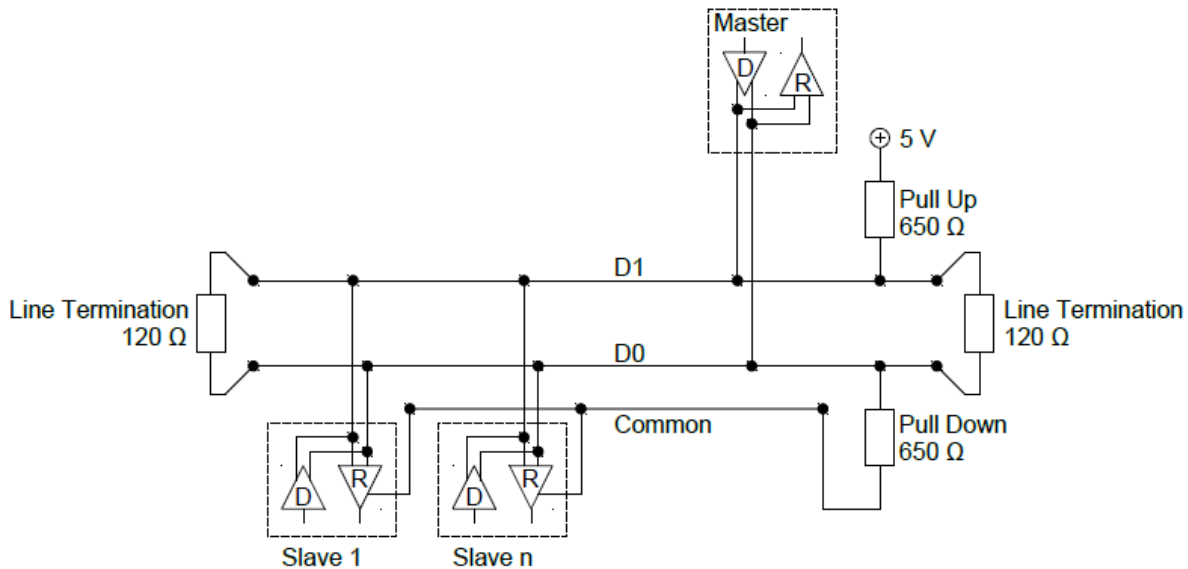

Changing CANopen NodeID

- Check object 2009_h for current CANopen NodeID.
 - Default NodeID = 14_d = E_h
- Write desired NodeID value to 2009_h.
 - Software Version 11 & above: Acceptable NodeID value range = 1_d-23_d (Defaults to 14 if node ID is out of range)
 - Software Version 10 & below: Acceptable NodeID value range = 1_d-127_d
- To save, write to object 1010_h sub-index 0A_h the value 1702257011_d (65766173_h).
- Wait until object 1010_h sub-index 0A_h is equal to 1.
- Disconnect and reconnect power.
- The device NodeID will now be changed.

Changing CANopen Baud Rate

Please consult integration/assembly manual 1101334 for instructions on changing the CANopen baud rate. Available baud rates are 10, 20, 50, 125, 250, 500, and 1000 kBaud.

CANopen I/O Service Data Objects (SDO's) and Functionality

| Type | Object (hex) | Sub Index (hex) | Short Name | Description |
|--------|--------------|-----------------|-------------------------|---|
| Inputs | 2400 | 01 | Move Enable | 1 = home magnet 2 = move to position set in 2400:02 0 = reset trigger after each move |
| | 2400 | 02 | Set Position | Position 0-100% (increments of 1) |
| | 2400 | 03 | Calibration Trigger | Standard Calibration: 1 = trigger (must be reset to 0 after each trigger in standard calibration) Auto Calibration: 1 = start (with Calibration Mode already set to 1) 999 = exit & don't save 0 = reset trigger after setting 1 or 999 |
| | 2400 | 04 | Calibration Select | Select calibration storage options 0-3 (4 possible calibrations) |
| | 2400 | 05 | Sensitivity | default = 0 more sensitive = -x less sensitive = x typical x values = 5, 10, 20 |
| | 2400 | 06 | Calibration Mode | 0 = standard calibration procedure (good for bin picking, etc) 1 = auto calibrate |
| | Outputs | 2500 | 01 | Magnet Position |
| 2500 | | 02 | Magnet State | 0 = OFF 1 = Partial ON 2 = Magnet ON 100% (Fail-Safe) |
| 2500 | | 03 | Calibration State | 0 = no South Pole, no North Pole, and no part present in range 4 = North, South, part present all within Range |
| 2500 | | 04 | In Calibration | 0 = not in Calibration 1 = In Standard Calibration 2 = In Auto Calibration |
| 2500 | | 05 | Calibration Step | 0 = not in calibration 1 = waiting for best circuit 2 = waiting for worst circuit 3 = waiting for South Pole 4 = waiting for North pole |
| 2500 | | 06 | Cycle Count | Number of times the tool has been turned on to full power |
| 2500 | | 07 | Home Status | 0 = not properly homed 1 = Properly homed |
| 2500 | | 08 | Move Status | 0 = not complete 1 = Last set move complete |
| 2500 | | 09 | Serial Number | Magswitch Tool Serial Number |
| 2500 | | 0A | Magnet Software Version | Magswitch Software Version |
| 2500 | | 0B | Tool Type | 30 for E30, 50 for E50, 505 for ELAY50x5 |
| 2005 | | | CANopen Baud Rate | 84 _h = 132 _d = 125 kBaud by default. Consult configuration manual 1101334 before changing |
| 2009 | | | CANopen Node ID | Refer to Pg. 5: Step 2a and 2b for more details on NodeID range E _h = 14 _d by default |

2-Step Calibration Procedure

See setup manual 1101334 for more E-series detail.

Step 1

Limiting Position 1 for Calibration Match Signal

Step 2

Limiting Position 2 for Calibration Match Signal

Object **CalState (2500:03_h)** will return 4 when the contact quality between both poles and the part lie within the zone created by bounding Limiting Position 1, Limiting Position 2, and North and South Pole calibration signals.

NOTE: North and South pole calibration steps 3 and 4 typical of the E30 and E50 tools are removed from the ELAY calibration procedures. This is because the north and south poles of an ELAY tool are elongated, and in most customer applications it is difficult to position the long edge of the magnet near the edge of the part without also impacting the calibration of the opposite pole.

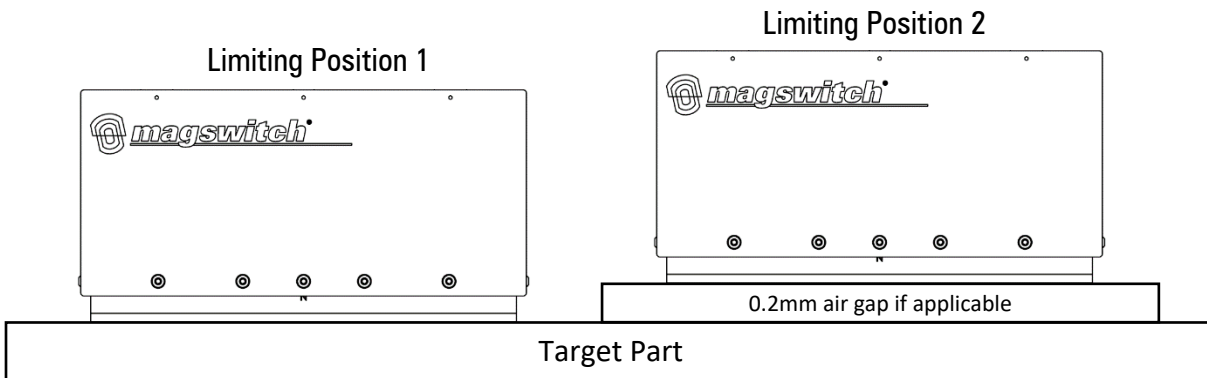

The following flowchart shows the proper CANopen signaling required to enter and set calibrations 0-4. Note that all “output” objects can be polled at any time to determine the current state of the calibration process.

It is critical that the magnet be fully actuated ($\text{setPosition} / \text{OutPos} = 100$) at each calibration step to guarantee proper field values are stored. **The tool will not allow you to confirm calibration steps 1 and 2 unless the magnet is ON and the green light is lit.**

The supplementary document 1101340 can be provided by Magswitch if additional information regarding calibration procedure is needed.

Auto-Calibration Procedure

Actuate tool OFF and enter auto-calibration mode by setting object $2400:04 = 1_d$ and then writing $2400:03 = 1_d$. Position the tool on the desired part. Once the tool is actuated ON and the green light is lit, the tool records magnetic field strengths in the current configuration and stores them as allowable Part Present boundaries. Add or adjust parts and fixtures to widen the allowable range of field strengths. By writing $2400:03 = 0_d$, auto-calibration parameters are saved and standard operation resumes. Tool should NOT be actuated OFF until auto-calibration is exited and saved otherwise calibration values will be skewed. Tool should not be actuated off-target or calibration range will exceed practical usage and part present functionality will be inaccurate.

E-Series Operational Flowchart

