

PLAY50X2 2.0 | P/N: 81401515

Summary

The Magswitch 2.0 LAY-series of magnetic grippers for robotic automation utilize magnets arranged in a linear array to extend the depth and footprint of the magnetic field. The larger footprint of the array magnets provide stability for large end effectors and workpieces. With the ability to add custom pole shoes, the LAY magnets can be used with many different part profiles. The LAY 2.0 tools are strong, robust, and a perfect material handling solution for handling pipe, tubes and plate steel.

Specifications

Maximum Breakaway Force ^{1,2,4}	4614	N		
Maximum Shear ^{1,2,4}	1128	N		
Minimum Thickness for De-Stack ³	0.500	in	12.7	mm
Overall Height (Max)	11.8	in	300.5	mm
Overall Length	11.2	in	285.6	mm
Overall Width	4.9	in	125.0	mm
Net Weight	14.33	lbs	6.5	kg
Magnetic Pole Footprint	3.8x10.0	in	97.6x255	mm
Max Allowable Pressure	145	psi	1.00	MPa



Material Thickness - mm (in)	1 (0.039)	2 (0.079)	3 (0.118)	4 (0.157)	5 (0.197)	6 (0.236)	7 (0.276)	9.53 (0.375)	12.7 (0.500)	19.05 (0.750)	50 (1.969)
Maximum Force ⁵ (N)	465	838	1345	1756	2537	3071	3392	4007	4311	4614	4614
Required Air Pressure - bar (psi)	2.8 (40)	2.4 (35)	2.2 (32)	2.1 (30)	1.9 (27)	1.7 (24)	1.5 (22)	1.4 (20)	1.4 (20)	1.4 (20)	1.4 (20)

¹ Determined in laboratory environment on 2" thick SAE1018 Steel with surface roughness 63 micro inches. Many factors contribute to the actual breakaway force and safe working load in each application. Consult a Magswitch Applications Engineer and test the Magswitch in each application before deployment.

² All data applies to standard tool.

³ Determined with SAE1018 Steel L=200mm W=200mm.

⁴ Values may vary by +/- 5%.

⁵ Maximum forces listed above are not safe lifting forces. Designer must take into account safety factor when specifying tool. Magswitch recommends SWL = 5:1 for most applications.

$$SWL \text{ (Safe Working Load)} = \frac{\text{Maximum Force}^5}{\text{Safety Factor} (\geq 5)}$$

Pole shoes required for operation

Standard kits available:

Flat Pole Shoe Kit (Included)	88001720
135Deg V Pole Shoe Kit	88001721
155Deg V Pole Shoe Kit	88001722
Flat w/ Teeth Pole Shoe Kit	88001723

WARNING!

Do Not Operate Unless In Contact With Ferrous Target

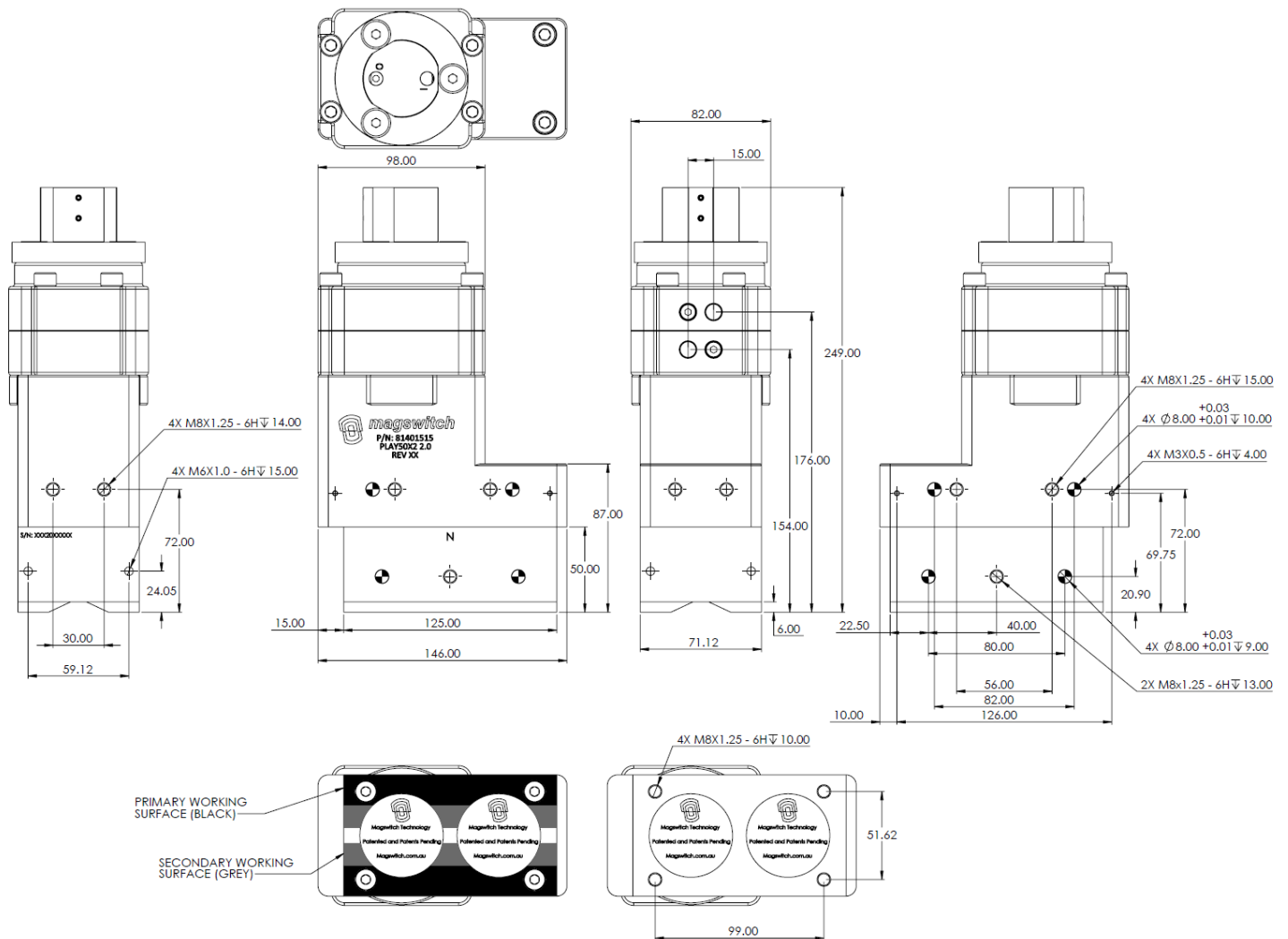

Center of Mass

