

PLAY70X4 2.0 | P/N: 81401520

Summary

The Magswitch 2.0 LAY-series of magnetic grippers for robotic automation utilize magnets arranged in a linear array to extend the depth and footprint of the magnetic field. The larger footprint of the array magnets provide stability for large end effectors and workpieces. With the ability to add custom pole shoes, the LAY magnets can be used with many different part profiles. The LAY 2.0 tools are strong, robust, and a perfect material handling solution for handling pipe, tubes and plate steel.

Specifications

Maximum Breakaway Force ^{1,2,4}	17366	N		
Maximum Shear ^{1,2,4}	4218	N		
Minimum Thickness for De-Stack ³	0.500	in	12.7	mm
Overall Height (Max)	11.8	in	300.5	mm
Overall Length	14.4	in	366.0	mm
Overall Width	4.9	in	125.0	mm
Net Weight	56.22	lbs	25.5	kg
Magnetic Pole Footprint	3.8x13.2	in	97.6x336	mm
Max Allowable Pressure	145	psi	1.00	MPa

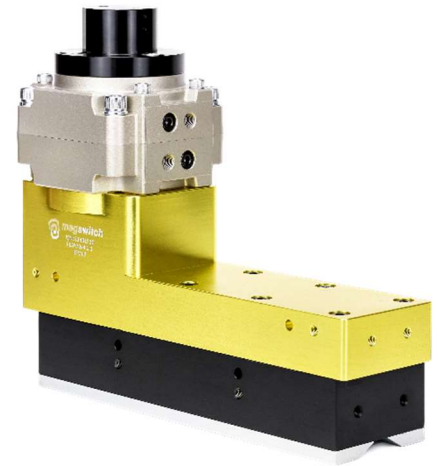

Material Thickness - mm (in)	1.5 (0.059)	1.9 (0.075)	2.7 (0.106)	3 (0.118)	3.5 (0.138)	4.76 (0.187)	6.35 (0.250)	9.53 (0.375)	12.7 (0.500)	19.05 (0.750)	50 (1.969)
Maximum Force ⁵ (N)	1622	1915	3302	3505	4295	7190	8808	14501	15438	16944	17366
Required Air Pressure - bar (psi)	4.5 (65)	4.1 (60)	3.9 (56)	3.6 (52)	3.1 (45)	2.8 (40)	2.6 (38)	2.4 (35)	2.2 (32)	2.2 (32)	2.2 (32)

¹ Determined in laboratory environment on 2" thick SAE1018 Steel with surface roughness 63 micro inches. Many factors contribute to the actual breakaway force and safe working load in each application. Consult a Magswitch Applications Engineer and test the Magswitch in each application before deployment.

² All data applies to standard tool.

³ Determined with SAE1018 Steel L=200mm W=200mm.

⁴ Values may vary by +/- 5%.

⁵ Maximum forces listed above are not safe lifting forces. Designer must take into account safety factor when specifying tool. Magswitch recommends SWL = 5:1 for most applications.

$$SWL \text{ (Safe Working Load)} = \frac{\text{Maximum Force}^5}{\text{Safety Factor} (\geq 5)}$$

Pole shoes required for operation

Standard kits available:

Flat Pole Shoe Kit (Included)	8800079
135Deg V Pole Shoe Kit	88001713
155Deg V Pole Shoe Kit	88001714
Flat w/ Teeth Pole Shoe Kit	88001715

WARNING!
Do Not Operate Unless In Contact With Ferrous Target

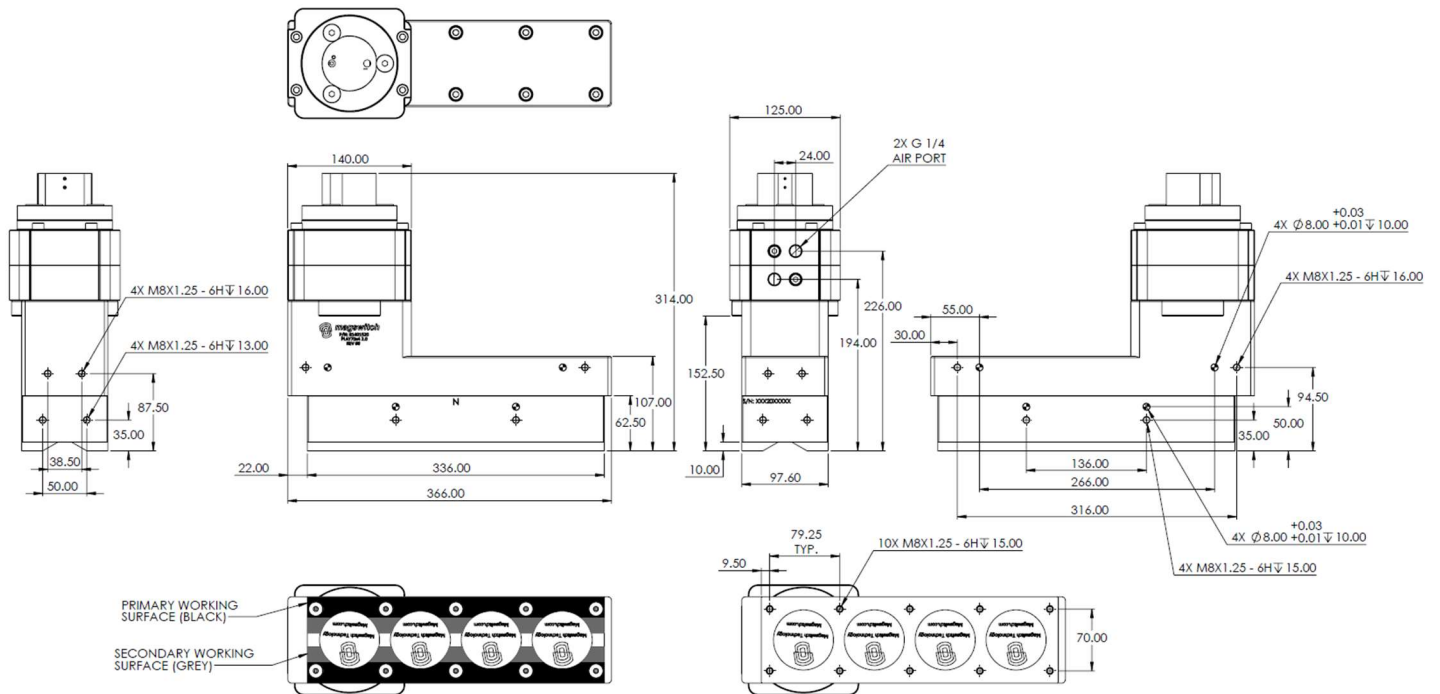

Center of Mass

