

D12 | P/N: 81401541

The D12 is specifically designed for the delicate handling of small parts. Equipped with cutting-edge shallow field array technology, it excels as an exceptional solution for effortlessly de-stacking and lifting thin materials, a task that often proves challenging for conventional magnets.

WARNING!
Do Not Operate Unless In Contact With Ferrous Target

Specifications

Maximum Breakaway Force (Without Friction Pad) ¹	118 N	
Maximum Breakaway Force (With Friction Pad) ¹	111 N	
Maximum Shear Force (Without Friction Pad) ¹	43 N	
Maximum Shear Force (With Friction Pad) ¹	49 N	
Thickness for De-Stack ²	0.059 in	1.5 mm
Maximum Allowable Pressure	145 psi	10.0 Bar
On Target Actuation Pressure (Full Saturation)	57 psi	3.9 Bar
Air Port Threads	2x G1/8 (1/8 BSP)	
Net Weight	0.4 lb	0.2 kg
Individual Magnetic Pole Footprint	0.91" x 0.91"	23mm x 23mm
Mounting Options	3x Side: Ø3-M4-Ø3-M4 1x Top (center): G1/8 1x Top: Ø3-M5-Ø3-M5	



Material Thickness - mm (in)	0.5 (0.020)	1.0 (0.039)	2.0 (0.079)	3.0 (0.118)
Maximum Force ¹ Without Friction Pad - Newton (N)	44	90	118	118
Maximum Force ¹ With Friction Pad - Newton (N)	35	88	111	111
Required Air Pressure ³ Without Friction Pad - Bar (psi)	2.4 (35)	3.4 (50)	3.9 (57)	3.9 (57)
Required Air Pressure ³ With Friction Pad - Bar (psi)	2.4 (35)	3.4 (50)	3.9 (57)	3.9 (57)

¹ Determined in laboratory environment on 2" thick SAE1018 Steel with surface roughness 63 micro inches with optimized pole shoes. Many factors contribute to the actual breakaway force and safe working load in each application. Consult a Magswitch Applications Engineer and test the Magswitch in each application before deployment.

² Tested and Determined with Two SAE1018 Steel Sheets L=200mm W=200mm Thickness=1.5 mm.

³ Values may vary by +/- 5%.

⁴ Maximum forces listed above are not safe lifting forces. Designer must take into account safety factor when specifying tool. Magswitch recommends SWL = 5:1 for most applications.



MAGSWITCH D12
 P/N: 81401541
 + 1(303) 468.0662
 magswitch.com

Tool and Sensor Bundle Kit Available:

Magswitch D12 with Sensor Kit (sensor installed)	88001584
--	----------

Standard Kits Available:

D5/D12 Friction Pad Kit (included and pre-installed)	88001560
D5/D12 Rubber Band Kit (included in package)	88001558
D5/D12 Sensor Kit (sold separately)	88001580
D5/D12 28.5mm Ball Mount Kit (sold separately)	88001562

Note: Magswitch D12 (81401541) does NOT come with Sensor Kit (88001580). 88001584 is the bundle kit of D12 with Sensor Kit installed.

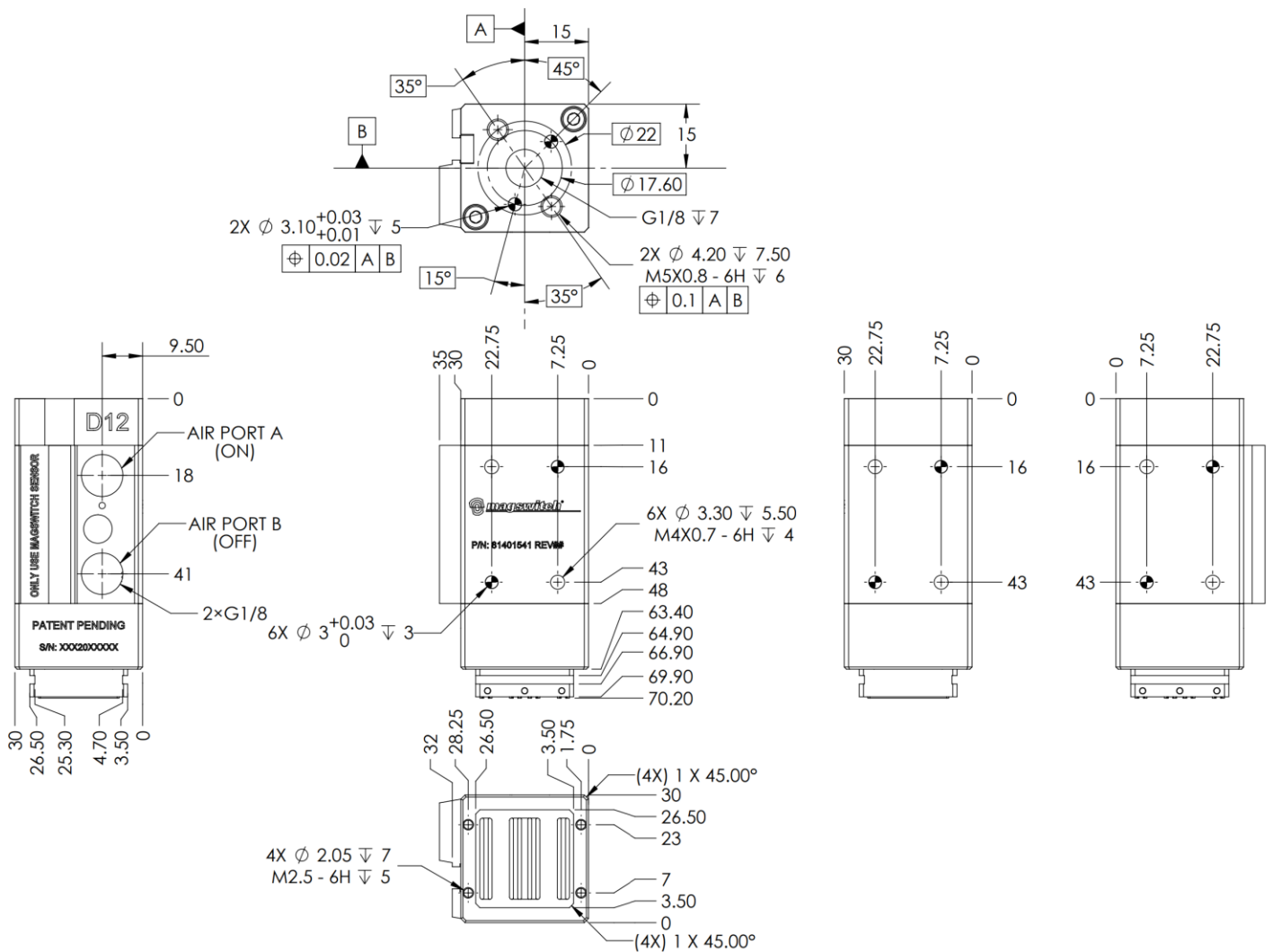

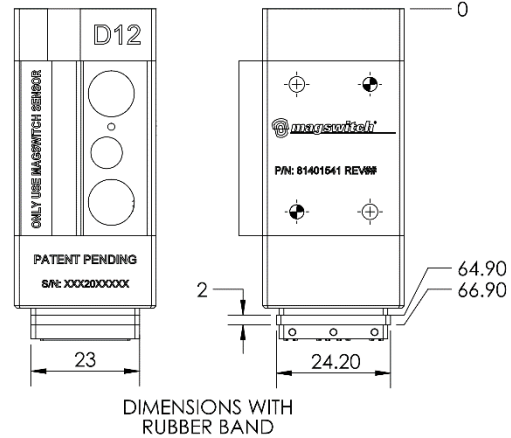
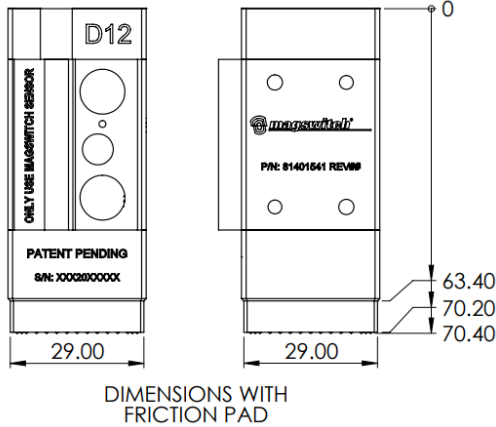

Sensor Kit Installation and Calibration

- Step 1
 - Connect tool to air supply.
 - Actuate to ON position while on target.
 - Insert Sick sensor (Magswitch PN 88001580 - sold separately) into T-slot and turn the sensor to parallel with T slot.
 - Push the sensor to the bottom of T slot and tighten screw to secure sensor.

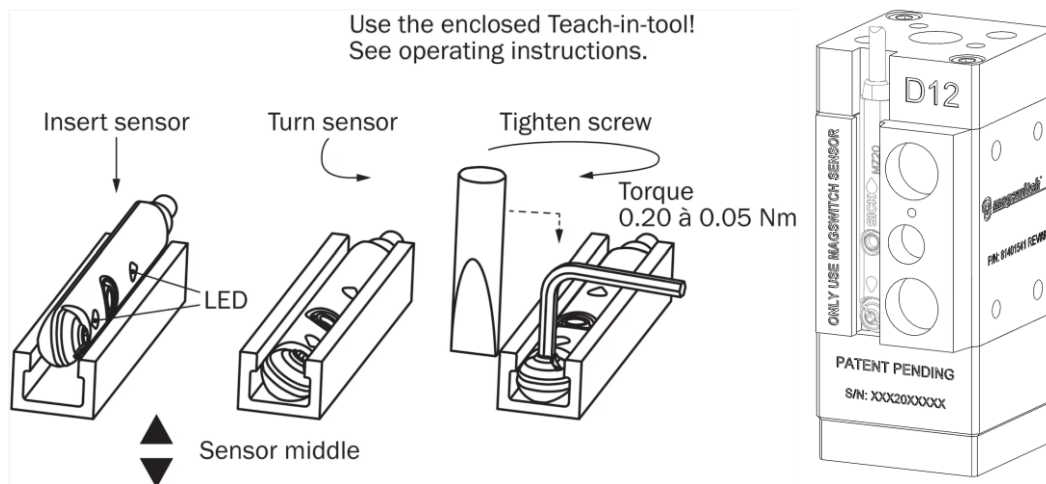

- Step 2
 - Using a non-ferrous object, press and hold the button in the center of the sensor for 3 seconds.
 - The lower light will blink to indicate that you can release.
 - The lower light will remain lit while the top light blinks continuously.

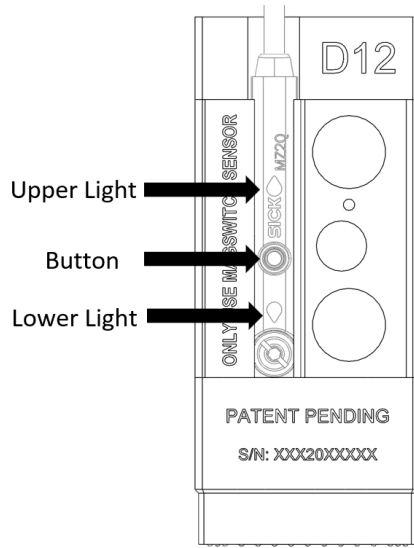

- Step 3
 - Actuate tool to OFF position, the lower light should turn off.
 - Using a non-ferrous object, press the button momentarily.
 - The upper light will blink and stay on.
 - The sensor is now calibrated.
 - Actuate the tool on and off several times to confirm functionality.

Wiring Diagrams

88001580 – KIT, SENSOR, D5 AND D12

Dimensional drawing Cable with connector M12, with knurled nuts

Dimensions in mm (inch)

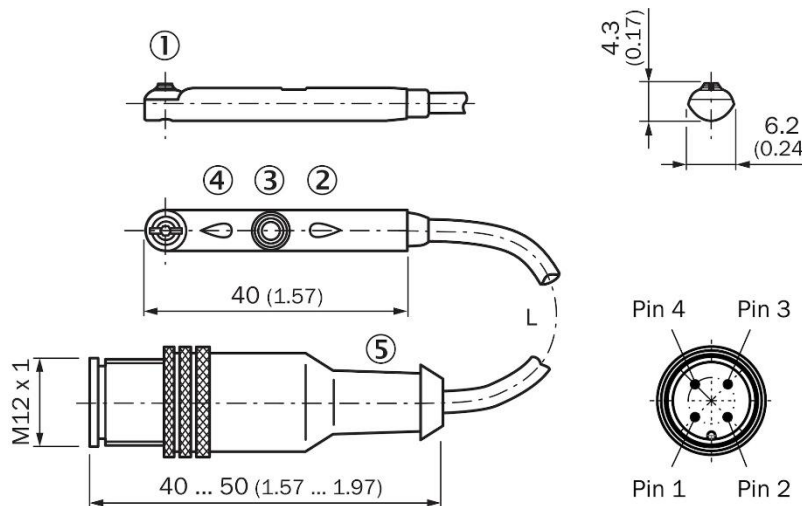

L = 300m; Number of Cores = 4

① Fixing screw SW 1.5 ② Display LED ③ Teach-in button ④ Display LED ⑤ Connection

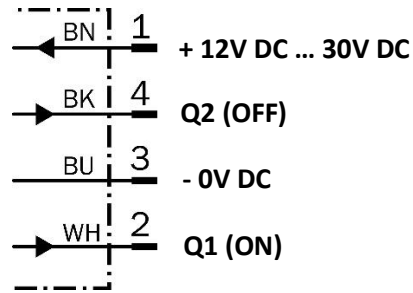
Connection diagram Cd-032

Rubber Band Kit Installation

NOTE: The tool comes with Friction Pad Kit (pre-installed) and Rubber Band Kit (packed separately in the package). If you don't need Friction Pad Kit, remove it, and install the Rubber Band Kit instead. The tool must be used with either Friction Pad Kit or Rubber Band Kit. Follow the instruction below for the Rubber Band Kit installation.

- Turn OFF the tool.
- Remove Friction Pad Kit (pre-installed on the tool).
- Clean all the surfaces that will be covered by Rubber Band. Particles and debris should be removed completely.
- Align the two sides with thicker walls on the Rubber Band with two sides with slots on the tool (marked with arrows). Press in one side and then press in the other side.
- Press on the outside of Rubber Band along the lips several times until the lips are fully engaged into the slots.
- The installation of Rubber Band is complete.

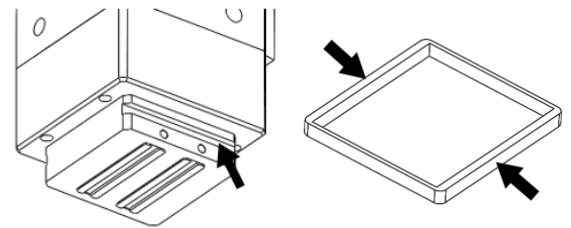

Friction Pad Kit Installation

NOTE: The Friction Pad Kit is pre-installed. If Friction Pad re-installation is needed, follow the instructions below.

- Turn OFF the tool.
- Remove the Rubber Band Kit (if applicable).
- Clean all the surfaces that will be covered by Friction Pad. Particles and debris should be removed completely.
- Align the two sides with lips on the Friction Pad with two sides with slots on the tool (marked with arrows). Press in one side and then press in the other side.
- Press on the outside of Friction Pad along the lips several times until the lips are fully engaged into the slots.
- The installation of Friction Pad is complete.

