

D120 COMPLIANCE DEVICE | P/N: 88001639

Summary

The D120 Compliance Device is an accessory to the D120 (sold separately). The compliance device simplifies setup for the D120 by compensating for part variation and can be used for flat and near flat contact, NOT for extreme deviation (round parts). Consider units with customizable pole geometries in these scenarios instead. Angular compliance is allowed on the X and Y axes as well as vertical compression about the Z axis. The additional flexibility also improves handling of sagging sheets ensuring the maximum performance in each application. It also imparts a dampening effect against accelerations.



Specifications

Net Weight (Compliance Device Only)	1.38 lb	0.63 kg
Pitch Forward/Backward (X-axis)	+/-4.5°	
Roll Left/Right (Y-axis)	+/-4.5°	
Yaw Clockwise/Counterclockwise (Z-axis)	Negligible Movement	
Z-axis Compression	-5mm	
X-axis or Y-axis Lateral Movement	+/-1.5mm if in compression	
Dimensions (Compliance Device Only)	80mm x 76mm x 50.67mm	

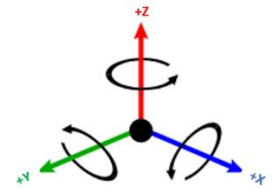

Compatible Tool Available:

D120 (sold separately)	81401457
Soft spring (included, installed)	1802516
Hard spring (included, packed separately)	1802178

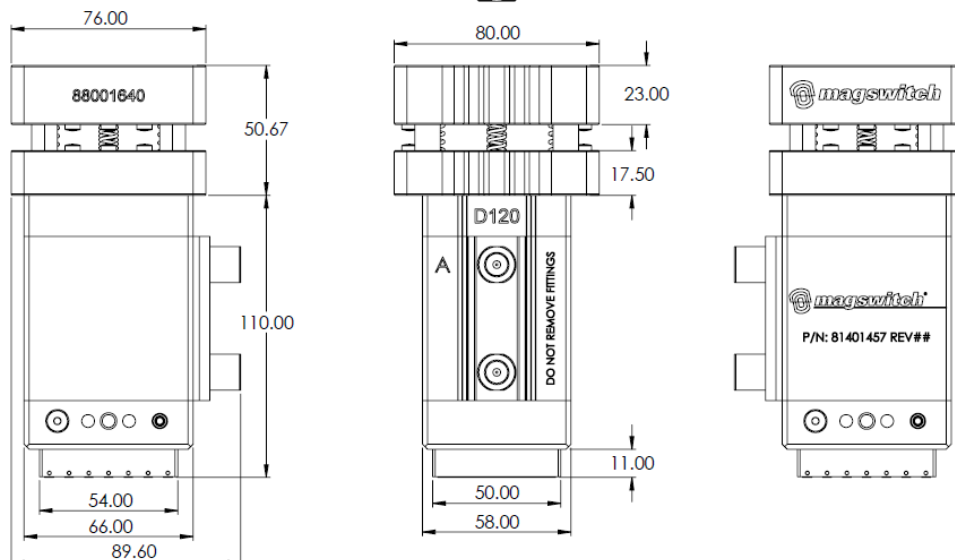
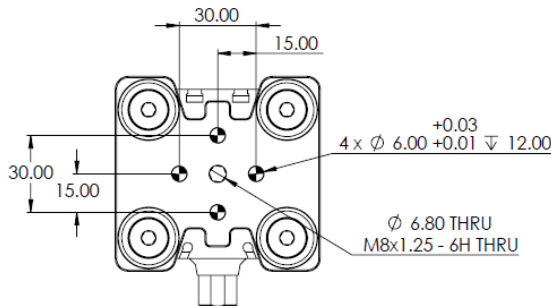

Installation Instructions

- Switch the D120 tool to the OFF state.
- Remove the D120 tool from preexisting mounting surfaces as required to expose top surface of the tool. Ensure dowel holes are clean. Confirm the top surface of the tool is flat and smooth.
- Insert two dowel pins into the dowel holes on the bottom of Compliance Device. Apply Thread Locking Compound on the thread of M8 Socket Head fastener.

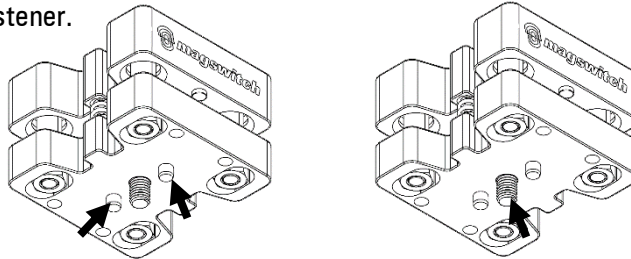

- Install the Compliance Device on top of D120. Align two dowel pins with the dowel holes on top of D120 (Set the direction as needed). Insert dowel pins until the Compliance Device is flush against D120.

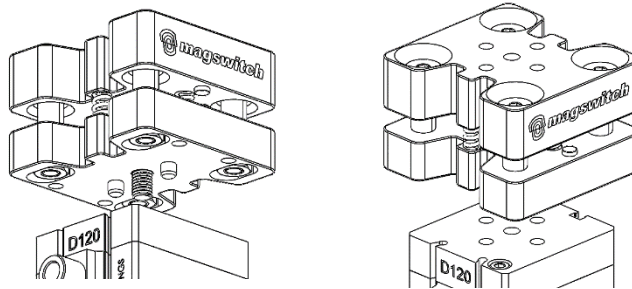

- Insert 6mm Hex Driver through the center hole on top of Compliance Device. Thread and tighten the fastener through the bottom plate into the threaded bore on top of D120. Torque the fastener to 41Nm.

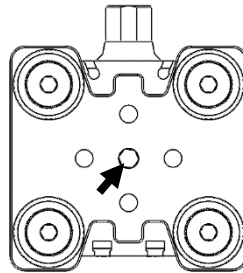

- The installation of D120 Compliance Device is complete. There should be no visible gaps between the D120 tool and the Compliance Device.

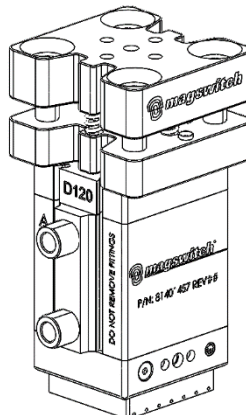

*Note: Please contact your sales representative for information regarding spring replacement.