

# MAGJIG 95 | P/N 8110004

## Summary

Magswitch MagJigs are ideal for downward pressure clamping. All MagJigs come with a 3/4" standoff for flush mount. Simply drill a hole in the fixturing material and place the clamp in. The MagJigs come with screw holes so you can secure the jig in the fixture. We recommend at least two MagJigs per fixture to minimize slippage. Create fences, assembly jigs, cutting fixtures, blade guards, work supports or anything that makes your work faster, safer and easier.

**WARNING!**

**Do Not Operate Unless In Contact With Ferrous Target**

## Specifications



Maximum Breakaway Force <sup>1</sup>	304 N	
Maximum Shear <sup>1</sup>	88.3 N	
Net Weight	0.2 lb	0.1 kg
Full Saturation Thickness	0.125"	3.2 mm
Magnetic Pole Footprint	1.2" x 0.8"	30mm x 21mm

Material Thickness - mm (in)	0.4 (0.02)	0.5 (0.02)	0.6 (0.02)	0.8 (0.03)	1 (0.04)	1.2 (0.05)	1.5 (0.06)	1.9 (0.07)	2.7 (0.11)	3 (0.12)	3.5 (0.14)	4.76 (0.19)	6.35 (0.25)
Maximum Force <sup>1,2</sup> - Newtons (N)	36.6	51.3	58.8	81.4	109.5	114.1	161.8	243.2	273.9	297.8	301.1	301.1	302.3

<sup>1</sup> Determined in laboratory environment on 2" thick SAE1018 Steel with surface roughness 63 micro inches. Many factors contribute to the actual breakaway force and safe working load in each application. Consult a Magswitch Applications Engineer and test the Magswitch in each application before deployment.

<sup>2</sup> Determined with SAE1018 Steel L=200mm W=200mm.

<sup>3</sup> Values may vary by +/- 5%.

<sup>4</sup> Maximum forces listed above are not safe lifting forces. Designer must take into account safety factor when specifying tool. Magswitch recommends SWL = 5:1 for most applications.

$$SWL \text{ (Safe Working Load)} = \frac{\text{Maximum Force}^4}{\text{Safety Factor} (\geq 5)}$$

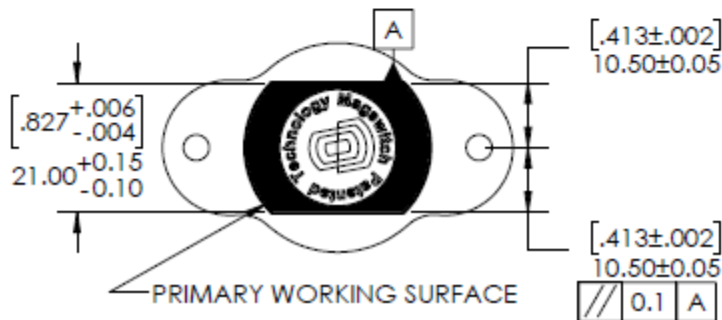
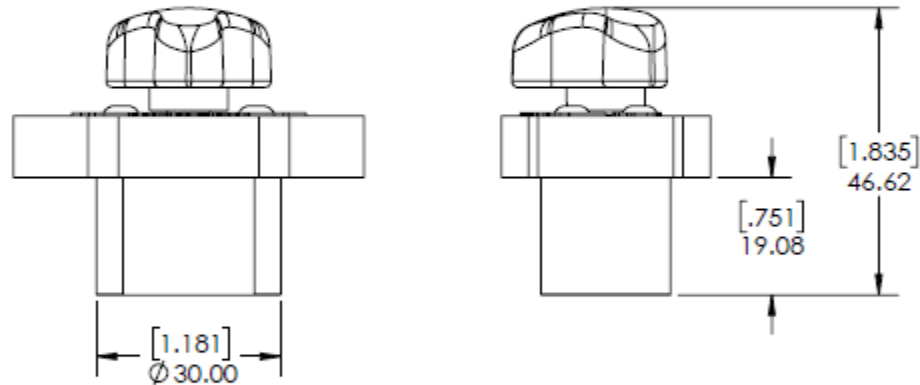
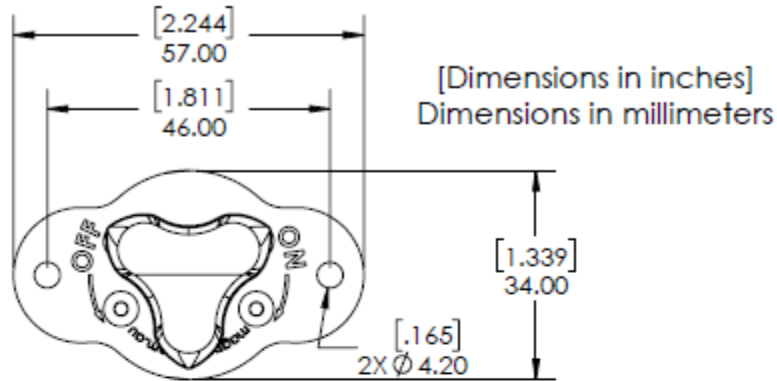

ISO 2768-M	
SIZE (mm)	TOLERANCE
0.5 - 3	±0.1
>3 - 6	±0.1
>6 - 30	±0.2
>30 - 120	±0.3
>120 - 400	±0.5
>400 - 1000	±0.8
>1000 - 2000	±1.2